

# CHCNAV<sup>®</sup> P5<sup>™</sup> GNSS Reference Receiver User Guide

Revision 1.0  
03/16/2021

# Table of Contents

<b>Table of Contents</b> .....	<b>2</b>
<b>Safety Information</b> .....	<b>4</b>
Regulations and Safety .....	4
Type Approval .....	4
Exposure to Radio Frequency Radiation.....	4
Battery Safety.....	5
DC Power Supply Safety.....	6
Wet Location Safety.....	6
<b>1 Introduction</b> .....	<b>7</b>
1.1 About the Receiver .....	7
1.2 Technical Support .....	7
1.3 Disclaimer.....	8
1.4 The User’s Comments .....	8
<b>2 Overview</b> .....	<b>9</b>
2.1 Receiver Framework .....	9
2.1.1 The Network Appliance Concept .....	10
2.2 Receiver Services .....	10
2.3 Receiver Features.....	11
2.4 Use and Care .....	12
2.5 Electronic Interface .....	12
2.6 Keypad and Display .....	13
2.7 Rear Connectors.....	14
<b>3 Batteries and Power</b> .....	<b>15</b>
3.1 External Power .....	15
3.2 Battery Safety.....	16
3.3 Battery Performance.....	16
3.4 Charging the Battery .....	17
3.5 Storing the Battery .....	17
3.6 Removing the Battery .....	18
<b>4 Setting Up the Receiver</b> .....	<b>19</b>
4.1 Guidelines .....	19
4.1.1 Environmental Conditions .....	19
4.1.2 Sources of Electrical Interference .....	19
4.1.3 Uninterruptible Power Supply .....	20
4.1.4 Lighting and Surge Protection.....	20
4.1.5 Placing the Antenna .....	20
4.2 System installation .....	21
4.2.1 Supported Antenna.....	21
4.2.2 System Installation Diagram .....	22

<b>5 Configuring the Receiver: Keypad, Indicator LEDs, and Display.....</b>	<b>25</b>
5.1 Button Functions.....	25
5.2 Indicator LEDs .....	26
5.3 Home Screen .....	26
5.4 Status Screens .....	27
5.5 Setting Up the Receiver as Part of An Ethernet Configuration.....	28
<b>6 Configuring the Receiver: Other Than Keypad and Display .....</b>	<b>29</b>
6.1 Configuring the Ethernet Settings .....	29
6.2 Configuring through A Web Browser .....	30
6.2.1 Changing the Settings .....	31
6.2.1.1 Status Menu .....	31
6.2.1.2 Satellites Menu .....	33
6.2.1.3 Receiver Configuration Menu .....	36
6.2.1.4 Data Recording Menu .....	41
6.2.1.5 I/O Settings Menu .....	47
6.2.1.6 Network Set Menu .....	53
6.2.1.7 Network Security Menu .....	55
6.2.1.8 Module Setting Menu .....	57
6.2.1.9 Firmware Menu .....	59
<b>7 Default Setting and Configuration Files.....</b>	<b>63</b>
7.1.1 Default Receiver Settings.....	63
7.1.2 Resetting the Receiver to Factory Defaults .....	64
7.1.3 Using Configuration Files to Duplicate Receiver Settings.....	64
<b>8 Specifications.....</b>	<b>66</b>
8.1 GNSS Characteristics .....	66
8.2 Communication.....	67
8.3 Physical.....	68
8.4 Electrical.....	68
8.5 General.....	69
8.6 Data storage.....	69
<b>A. Upgrading the Receiver Firmware .....</b>	<b>70</b>
A.I. Upgrading the Receiver Firmware.....	70
A.I.i. Upgrading through the USB Port.....	70
A.I.ii. Upgrading through A Browser .....	70
<b>B. Troubleshooting.....</b>	<b>71</b>
B.I. Receiver Issues.....	71
<b>C. Communication Ports Definition .....</b>	<b>73</b>
C.I. CHCNAV P5 Receiver COM (10-PIN LEMO Port) Definition .....	73
C.II. CHCNAV P5 Receiver DB9 Male Connector Definition .....	74
<b>D. Glossary .....</b>	<b>75</b>

## Safety Information

Before the user uses the user's CHCNAV® P5 GNSS reference receiver, make sure that the

user has read and understood all safety requirements.

## Regulations and Safety

The receiver contains an internal wireless modem for communicating signals through Bluetooth® wireless technology or through an external data communications radio. Regulations regarding the use of the wireless modem vary greatly from country to country. In some countries, the unit can be used without obtaining an end-user license. Other countries require end-user licensing. For licensing information, consult the user's local CHCNAV dealer.

Before operating a P5 GNSS reference receiver, determine if authorization or a license to operate the unit is required in the user's country. It is the responsibility of the end-user to obtain an operator's permit or license for the receiver for the location or country of use.

## Type Approval

Type approval, or acceptance, covers technical parameters of the equipment related to emissions that can cause interference. Type approval is granted to the manufacturer of the transmission equipment, independent from the operation or licensing of the units. Some countries have unique technical requirements for operation radio modem frequency bands. To comply with those requirements, CHCNAV may have modified the user's equipment to be granted Type approval. Unauthorized modification of the units voids the Type approval, the warranty, and the operational license of the equipment.

## Exposure to Radio Frequency Radiation

*Safety.* Exposure to RF energy is an important safety consideration. The FCC has adopted a safety standard for human exposure to radio frequency electromagnetic energy emitted by FCC-regulated equipment. Proper use of this radio modem results in an exposure below government limits. The following precautions are recommended:

- (1) **Do not** operate the transmitter when someone is 20 cm (7.8 inches) of the antenna.
- (2) **Do not** operate the transmitter unless all RF connectors are secured, and any open connectors are correctly terminated.
- (3) **Do not** operate the equipment near electrical blasting caps or in an explosive atmosphere.
- (4) All equipment must be correctly grounded for safe operation.
- (5) All equipment should be serviced only by a qualified technician.

## Battery Safety



**WARNING** – Do not damage the rechargeable Lithium-ion battery. A damaged battery can cause an explosion or fire and can result in personal injury and/or property damage. To prevent injury or damage:

- (1) Do not use or charge the battery if it appears to be damaged. Signs of damage include, but are not limited to, discoloration, warping, and leaking battery fluid.
- (2) Do not expose the battery to fire, high temperature, or direct sunlight.
- (3) Do not immerse the battery in water.
- (4) Do not use or store the battery inside a vehicle during hot weather.
- (5) Do not drop or puncture the battery.
- (6) Do not open the battery or short-circuit its contacts.



**WARNING** – Avoid contact with the rechargeable Lithium-ion battery if it appears to be leaking. Battery fluid is corrosive, and contact with it can result in personal injury and/or property damage. To prevent injury or damage:

- (1) If the battery leaks, avoid contact with the battery fluid.
- (2) If battery fluid gets into the user's eyes, immediately rinse the user's eyes with clean water and seek medical attention. Do not rub the user's eyes!
- (3) If battery fluid gets into the user's skin or clothing, immediately use clean water to wash off the battery fluid.



**WARNING** – Charge and use the rechargeable Lithium-ion battery only in strict accordance with the instructions. Charging or using the battery in unauthorized equipment can cause an explosion or fire and can result in personal injury and/or equipment damage. To prevent injury or damage:

- (1) Do not charge or use the battery if it appears to be damaged or leaking.
- (2) Charge the Lithium-ion battery only in a CHCNAV product that is specified to charge it.
- (3) Discontinue charging a battery that gives off extreme heat or a burning odor.
- (4) Use the battery only in CHCNAV equipment that is specified to use it.
- (5) Use the battery only for its intended use and according to the instructions in the product documentation.

## DC Power Supply Safety



**WARNING** – When DC voltage is applied to this receiver through COM port(LEMO connectors), the DC voltage must be limited to no more than 36 V DC +0% under both normal and single fault conditions. If the recommended input voltage is exceeded, the receiver may present an electrical hazard.

## Wet Location Safety



**WARNING** – This receiver is not intended to be used in a wet location, or a location that may become wet when it is powered by the external DC power supply. Use the receiver in a wet location **only** when operating it on its own internal battery.



**WARNING** – The external power adapter and its associated power cord and plug are not intended to be installed outdoors or in a wet location.



**WARNING** – Do not power the receiver through external power when operating in a wet environment or an environment that may become wet. The power input connections must be sheltered.

# 1 Introduction

The P5 GNSS Reference Receiver User Guide describes how to set up and use the CHCNAV® P5 GNSS reference receiver.

In this manual, “the receiver” refers to the P5 GNSS reference receiver unless otherwise stated.

Even if the user has used other Global Navigation Satellite Systems (GNSS) products before, CHCNAV recommends that the user spend some time reading this manual to learn about the special features of this product. If the user is not familiar with GNSS, go to [www.chcnav.com](http://www.chcnav.com) for an interactive look at CHCNAV and GNSS.

## 1.1 About the Receiver

The P5 GNSS reference receiver (“the receiver”) is a multiple-frequency GNSS receiver. It can track all GPS (L1/L2/L5), GLONASS (L1/L2), BDS (B1/B2/B3/B1c/B2a), GALILEO(E1/E5a/E5b), QZSS(L1/L5) and SBAS (L1).

The user can use the front panel of the receiver or an office computer to configure the receiver, access files, and publish data files to a company Intranet or to the Internet. The receiver makes it easy for the user to set up a powerful, flexible, and reliable reference station for continuous operation.

The receiver serves in all common geodetic reference receiver roles. It can be the main component in a Continuously Operating Reference Station (CORS), streaming data to CHCNAV GNSS Infrastructure software. It can also work well as a campaign receiver prior to permanent deployment. The receiver makes an excellent portable RTK base station with its internal battery. It also has specialized capabilities that make it an excellent reference receiver for scientific applications.

## 1.2 Technical Support

If the user has a problem and cannot find the information the user needs in the product documentation or CHCNAV website ([www.chcnav.com](http://www.chcnav.com)), contact the user’s local CHCNAV dealer from which the user purchased the receiver(s).

If the user needs to contact CHCNAV technical support, please contact us by email ([support@chcnav.com](mailto:support@chcnav.com)) or Skype ([chc\\_support](https://www.skype.com)).

## **1.3 Disclaimer**

Before using the receiver, please make sure that the user has read and understood this User Guide, as well as the safety requirements. CHCNAV holds no responsibility for the wrong operation by users and for the losses incurred by the wrong understanding about this User Guide. However, CHCNAV reserves the rights to update and optimize the contents of this guide regularly. Please contact the user's local CHCNAV dealer for new information.

## **1.4 The User's Comments**

The user's feedback about this user guide will help us to improve it in a future revision. Please email the user's comments to [support@chcnav.com](mailto:support@chcnav.com).

## 2 Overview

This chapter introduces the P5 GNSS reference receiver (“the receiver”). This receiver makes it easy to set up a powerful and reliable Continuously Operating Reference Station (CORS) or to collect data from temporary field locations.

The receiver is ideal for the following infrastructure applications:

- (1) As part of a GNSS Infrastructure network in conjunction with CHCNAV Reference Station Network (CPS) software.
- (2) As part of a permanent reference station with or without supporting software.
- (3) A temporary field base station to broadcast RTK corrections and collect observations for post-processing.

### 2.1 Receiver Framework

The receiver integrates the multi-frequency GNSS technology into specialized processing and communications framework. The receiver can operate as a standalone reference station, or it can be integrated into a scalable network.

With an Internet Protocol (IP) as the primary communications method, the user can use public domain tools, such as a web browser and FTP client, to configure the receiver and access logged data files.

**Notes:** All references to the Internet refer to either a Wide Area Network (WAN) or a Local Area Network (LAN) connection.

The receiver adopts a secured system that requires a password protected login for configuration changes and/or file access.

Use the network management features to create a base/rover configuration with a variety of operating modes. The user can then enable those modes as necessary instead of switching the global state of the receiver from one mode to another. For example, the user can configure various streaming services with different configurations (such as any combination of the data stream, sample interval) on different TCP or UDP ports. To activate one or more modes, open the connection to the specific port. This allows multiple clients to access any given streaming service.

These features and many more, shift the model of a GNSS receiver toward the concept of a "network appliance".

## 2.1.1 The Network Appliance Concept

Traditionally, a GNSS receiver has one operator. That person is the only user of the receiver, so they can change settings without affecting other users.

With the P5 GNSS reference receiver, an operator can configure a receiver once, and then make it available as a network appliance for general use by one or more users (or clients).

This network appliance concept lets the user set up the receiver to provide one or more services that one or more users can access through a Local Area Network (LAN) or a Wide Area Network (WAN), such as the Internet. Once the receiver is set up, the user needs to make only minimal changes, if any, to the receiver configuration.

When the receiver is operating as a network appliance, it provides services to all users attached to the receiver through the network.

Different streaming services may be configured on different ports, for example, with different data rates or data combination. To obtain service, the client has only to connect to a specific port. In this way, most users do not need to control the receiver. Changing global settings, such as masks, will affect all users of all services.

The receiver provides the following standard configuration and data logging services:

Use...	To perform...
HTTP	All manual and automated configuration operations to manage the logged data file space.
FTP	Remote manual and/or automated operations to manage the logged data file upload path.

## 2.2 Receiver Services

The receiver can provide one or more streaming or query services over an RS-232 serial port or a TCP/IP port: Streaming service.

Anyone with authorized access can obtain streamed information, such as GNSS measurements or RTCM corrections, without having to control or issue commands to the receiver. The client simply connects to the port that is streaming the required information.

## 2.3 Receiver Features

- (1) 624-channels with all in view simultaneously tracked satellite signals:
  - a) GPS: L1, L2, L5
  - b) GLONASS: L1, L2
  - c) Galileo: E1, E5A, E5B
  - d) SBAS:L1
  - e) BDS: B1, B2, B3, B1c, B2a
  - f) QZSS:L1, L5
- (2) 32 GB internal data logging storage
- (3) External USB drive support
- (4) The internal battery provides up to 24 hours operation
- (5) Integrated display and keypad for system configuration without a controller
- (6) Integrated Bluetooth wireless technology for cable-free data transmission
- (7) Permanent/semi-permanent and mobile quick setup base station capability
- (8) The easy-to-use Web-interface menu system for rapid configuration and status checking
- (9) Rugged, weatherproof construction with an IP67 environmental rating
- (10) -40°C to +65°C (-40°F to +149°F) operating temperature range
- (11) 9 V to 36 V DC input power range
- (12) Data file generated in HCN
- (13) Eight independent data logging sessions with configurable memory pooling
- (14) Circulating data logging method
- (15) FTP push to allow uploading of logged data files to remote sites
- (16) Ethernet configuration through the front panel
- (17) Multiple languages available through the Web interface
- (18) NTRIP (Networked Transport of RTCM via Internet Protocol) client/server/caster support

## 2.4 Use and Care

This receiver can withstand the rough treatment and tough environment that typically occurs in CORS installation. However, it is a high-precision electronic instrument and should be treated with reasonable care.



**CAUTION** – Operating or storing the receiver outside the specified temperature range can damage it. For more information, see [Chapter 8 Specifications](#).

## 2.5 Electronic Interface

High-power signals from a nearby radio or radar transmitter can overwhelm the receiver circuits. This does not harm the instrument, but it can prevent the receiver electronics from functioning correctly.

Avoid locating the receiver or antenna within 400 meters of powerful radar, television, or other transmitters or GNSS antennas. Low-power transmitters, such as those in cell phones and two-way radios, normally do not interfere with receiver operations.

## 2.6 Keypad and Display

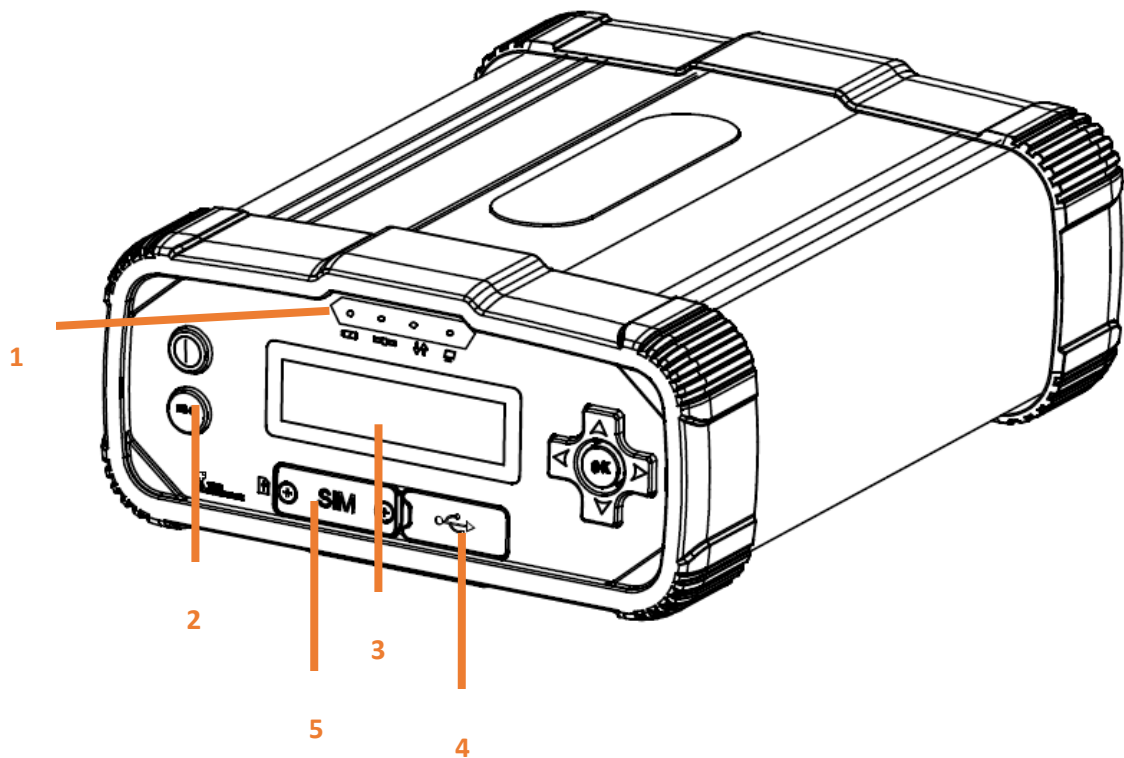

Feature	Description	Feature
Indicator LEDs	Shows the working status. See 5.2. Indicator LEDs	Indicator LEDs
Buttons	Use to turn on, turn off or configure the receiver. See 5.1. Button functions.	Buttons
Display	This LCD enables the user to view the current configuration settings of the receiver and the operation by operators. See 5.3. Home screen.	Display
Mini USB port	Support DEVICE/HOST.	Mini USB port
4G card slot	Insert 4G card to support mobile network	4G card slot

## 2.7 Rear Connectors

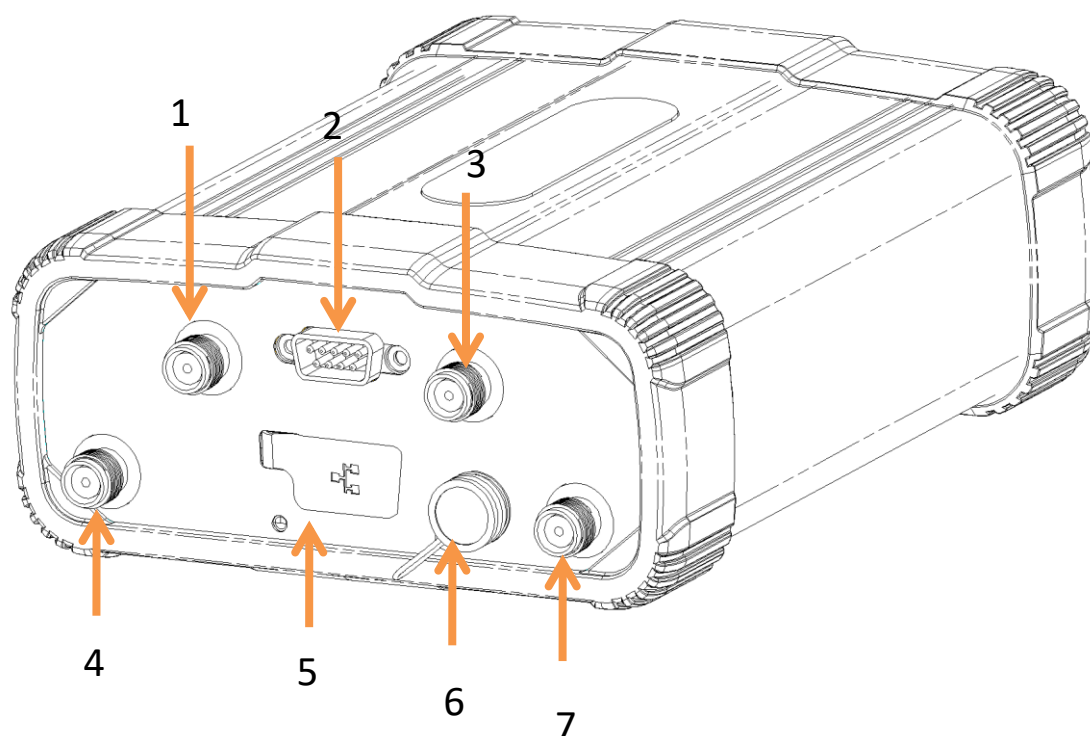

No.	Connector type	Description
1	TNC	Connect to the GNSS antenna.
2	DB9	RS-232 serial port, 9-pin male connector.
3	TNC	Connect the 4G antenna to enhance the 4G signal.
4	TNC	Connect to the atomic clock for time calibration.
5	RJ45 jack	Supports links to 10BaseT/100BaseT auto-negotiate networks HTTP, TCP/IP, UDP, FTP, NTRIP Caster, NTRIP Server, NTRIP Client Simultaneously transmits multiple data stream
6	LEMO (10-pin) Port 2	Power from an external AC/DC power supply. RS-232 serial communications using a 10-pin LEMO cable (CHCNAV Data Cable). Data streaming transmission port.
7	TNC	Connect to peripheral device for time calibration

## 3 Batteries and Power

The P5 GNSS reference receiver uses an internal rechargeable Lithium-ion battery, which can be replaced only at an Authorized CHCNAV Service Center.

The receiver can also be powered by an external power source that is connected to the LEMO ports.

The operational time provided by the internal battery depends on the type of measurement and operating conditions. Typically, the internal battery provides up to 24 hours operation.

**Notes:** All operational battery tests are carried out with new, fully-charged batteries at room temperature, tracking both GPS and GLONASS satellites while storing and streaming data at 1 Hz. Older batteries, at temperatures significantly higher or lower than room temperature, will have reduced performance. Power consumption increases with an increasing number of actively tracked satellites and with increasing observation and storage rates.

### 3.1 External Power

The receiver uses an external power source in preference to its internal battery. If the receiver is not connected to an external power source, or if the external power supply fails, the internal battery is used.

CHCNAV recommends that the applied external power offers between 9 V DC and 36 V DC and can supply at least 6.5 W of power for the long-term installations and ensure that the internal battery is charged and ready to compensate for power supply disruptions.

While carrying out static measurements for post-processed computations using the internal memory, if no external power is supplied and the internal battery is drained, the receiver shuts down. No data is lost; however, when power is restored, the receiver should be configured again.



**WARNING** – The external AC power adapter and its associated power cord and plug are not intended to be installed outdoors, nor in a wet location. Do not power the receiver through external power when operating in a wet environment or an environment that may become wet. The power input connections must be sheltered.



**WARNING** – When the user applies DC voltage to this product through the LEMO connector, the DC voltage must be limited to 36V DC +0% under both normal and single fault conditions. This product may present an electrical hazard if the recommended input voltage is exceeded.

## 3.2 Battery Safety

The receiver is powered by a rechargeable internal Lithium-ion battery. Charge and use the battery only in strict accordance with the following instructions.



**WARNING** – Do not damage the rechargeable Lithium-ion battery. A damaged battery can cause an explosion or fire and can result in personal injury and/or property damage.

To prevent injury or damage:

- (1) Do not use or charge the battery if it appears to be damaged. Signs of damage include, but are not limited to, discoloration, warping, and leaking battery fluid.
- (2) Do not expose the battery to fire, high temperature, or direct sunlight.
- (3) Do not immerse the battery in water.
- (4) Do not use or store the battery inside a vehicle during hot weather.
- (5) Do not drop or puncture the battery.
- (6) Do not open the battery or short-circuit its contacts.



**WARNING** – Avoid contact with the rechargeable Lithium-ion battery if it appears to be leaking. Battery fluid is corrosive, and contact with it can result in personal injury and/or property damage.

To prevent injury or damage:

- (1) If the battery leaks, avoid contact with the battery fluid.
- (2) If battery fluid gets into the user's eyes, immediately rinse the user's eyes with clean water and seek medical attention. Do not rub the user's eyes!
- (3) If battery fluid gets into the user's skin or clothing, immediately use clean water to wash off the battery fluid.

## 3.3 Battery Performance

To optimize battery performance and extend battery life:

- (1) Fully charge all new batteries before use.

- (2) Do not use at extreme temperatures. The receiver is designed to operate at -40 °C to +65 °C (-40 °F to +149 °F). However, operation at temperatures of less than 0 °C (32 °F) can cause a rapid drop in battery life.

### 3.4 Charging the Battery

The rechargeable Lithium-ion battery is supplied partially charged. Charge the battery completely before using it for the first time. If the battery has been stored for longer than three months, charge it before use.

When connected to a suitable power source, the internal battery charges fully in 10 hours.



**WARNING** – Charge and use the rechargeable Lithium-ion battery only in strict accordance with the instructions. Charging or using the battery in unauthorized equipment can cause an explosion or fire and can result in personal injury and/or equipment damage.

To prevent injury or damage:

- (1) Do not charge or use the battery if it appears to be damaged or leaking.
- (2) Charge the Lithium-ion battery only within the P5 receiver. The battery can only be removed by an authorized CHCNAV Service Center.

### 3.5 Storing the Battery

The internal Lithium-ion battery adopts a self-protection mechanism that protects the battery from discharge when its voltage is below 6 V and shuts down the receiver. The internal battery will be activated when charged by the external power supply.

Do not store the receiver at temperatures outside the range -40°C to +85 °C (4 0°F to 176° F).

The receiver is supplied with a mains power supply unit that recharges the battery inside the receiver when it is connected through the adaptor to either of the LEMO ports. When the user uses the receiver in a long-term installation, CHCNAV recommends that the user use this power supply or another that provides at least 9 V DC at all times to keep the internal battery charged. This will ensure that the internal battery provides an uninterrupted power supply that will keep the receiver operational for up to 24 hours after a power failure.

## **3.6 Removing the Battery**

The internal Lithium-ion battery may be removed only at an authorized CHCNAV Service Center. If the battery is removed at an unauthorized service center, the remaining warranty on the product will be void.

## 4 Setting Up the Receiver

This chapter describes best practices for setting up the equipment and outlines the precautions that the user must take to protect the equipment. It also describes the typical installation diagram of reference station composed of P5 GNSS receiver, GNSS antenna, external power and network cable.

The antenna installation guidelines described here are the *minimum* standards. When installing a geodetic antenna to gather precise observation data, always follow recommended CORS installation practices to the greatest extent possible.

### 4.1 Guidelines

When the user set up the receiver, follow these guidelines.

#### 4.1.1 Environmental Conditions

The receiver has a waterproof housing, but the user must take reasonable care to keep the unit dry.

To improve the performance and long-term reliability of the receiver, do not expose the receiver to extreme environmental conditions, such as:

- Water
- Heat greater than 65 °C (149 °F)
- Cold less than -40 °C (-40 °F)
- Corrosive fluids and gases

#### 4.1.2 Sources of Electrical Interference

Do not place the GNSS antenna near the following sources of electrical and magnetic noise:

- Gasoline engines (spark plugs)
- Televisions and computer monitors
- Alternators and generators
- Electric motors
- Equipment with DC-to-AC converters
- Fluorescent lights
- Switching power supplies
- Arc welding equipment

### 4.1.3 Uninterruptible Power Supply

CHCNAV recommends that the user use an uninterruptible power supply (UPS) to power the receiver. The internal battery can also operate as a UPS for up to 24 hours. A UPS protects the equipment from power surges and spikes and keeps the receiver running during short power outages.

For more information, contact the user's local CHCNAV dealer.

### 4.1.4 Lighting and Surge Protection

CHCNAV recommends that the user install lightning protection equipment at permanent sites. All connections to the receiver should have surge protection. Typically, the minimum protection should include a surge protector in the antenna feed line, on the receiver's power supply system. If serial devices are attached to the receiver, those serial connections should also be provided with surge protection. Also, protect any communications and power lines at building entry points. If the user uses other antennas, such as a radio modem that distributes real-time correction messages, install surge protection on those antenna feeds as well.

No surge protection devices can offer protection unless they are connected to an excellent ground using very low impedance conductors. Equipment damage caused by electrical surges occurs in many permanent installations even though surge protection is in place. Commonly, this is because the grounding system used was designed to protect against AC electrical hazards rather than to dissipate the sudden, high current surges caused by lightning. Please consult with a lightning protection expert or research the topic when planning permanent installations.

For more information, contact the user's local CHCNAV dealer.

### 4.1.5 Placing the Antenna

The antenna location will have a significant effect on the quality of the user's P5 receiver's performance. In temporary developments, it may not always be possible to set up in an ideal location with an excellent sky view. However, when installing a permanent station, be sure to plan the antenna location and mounting system carefully.

The general requirements for the antenna location and mount are:

- Keep the distance from the objects that may cause the multipath effects (such as buildings, trees, reflective surface) for at least 200 m (656 feet)
- Clear sky above 10 degrees elevation
- Away from electromagnetism interference region (e.g., Microwave station, radio

transmitting station, high voltage wires) at least 200 m (656 feet)

- Mounted 1.5 m (5 feet) above any nearby signal reflectors.
- Mount stability that is not influenced by thermal expansion, wind loading, or soil expansion/contraction.

For additional information on this topic, research the reference antenna installation guidelines published by the:

- US National Geodetic Survey
- ([http://www.ngs.noaa.gov/PUBS\\_LIB/CORS\\_guidelines.pdf](http://www.ngs.noaa.gov/PUBS_LIB/CORS_guidelines.pdf))
- International GNSS Service
- (<http://igscb.jpl.nasa.gov/network/guidelines/guidelines.html>)

## 4.2 System installation

### 4.2.1 Supported Antenna

The receiver provides a TNC-type female connector for connecting to an antenna. The receiver is intended for use with a CHCNAV Geodetic GNSS antenna or a CHCNAV GNSS Choke Ring antenna.

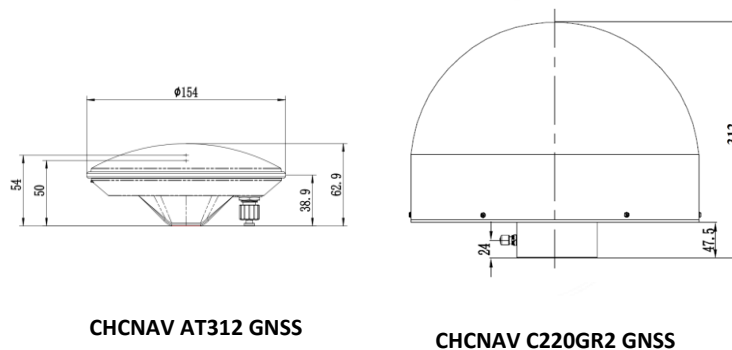

Other GNSS antennas may, however, be used ensuring that the antenna receives the proper GNSS frequencies and operates at either 3.3V or 7.1V with a signal greater than 40 dB at the antenna port.

## 4.2.2 System Installation Diagram

The typical installation diagram of the CHCNAV P5 GNSS receiver connected with CHCNAV A220GR GNSS Geodetic Antenna, external power supply, and network cable.

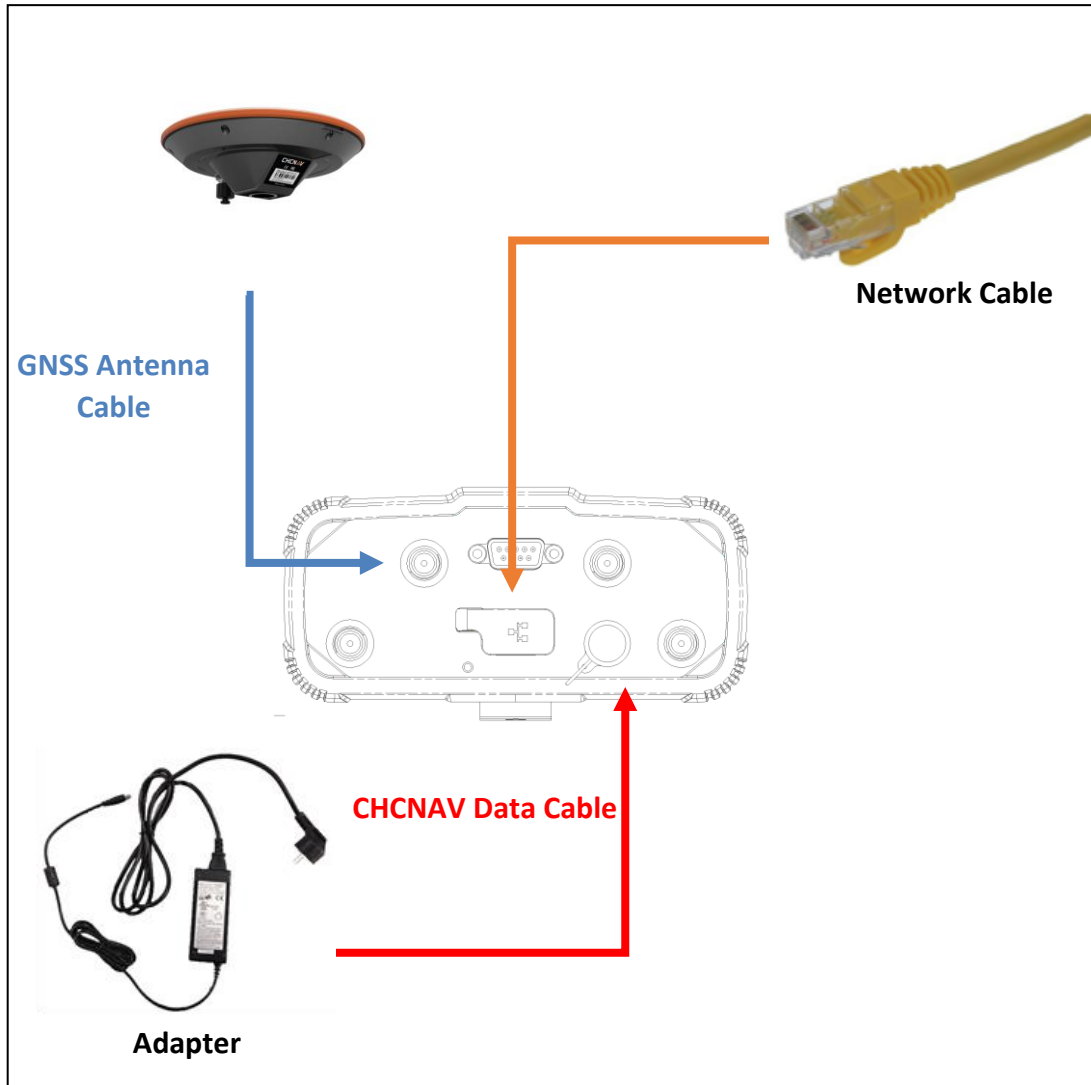

- (1) Install the GNSS antenna at the appropriate location (see 4.1.5. Placing the antenna for the guidelines); connect the antenna to the TNC Plug Socket of P5 via the GNSS Antenna Cable.
- (2) Power the P5 by an external power source (e.g., mains supply) with Adapter via CHCNAV Data Cable.



- a) Connect the 10-pin LEMO of CHCNAV Data Cable of P5.
- b) Plug the male jack connector Adapter into the female connector of CHCNAV Data Cable.

- c) Connect two leg plugs or three leg plugs of Adapter to the mains supply.
- (3) Connect the network cable to the RJ45 jack of P5 to link the P5 with the network.







**Notes:** Also, the P5 can be powered by external battery via CHCNAV Data Cable.  
And the power supply voltage should be controlled between 9 to 36 V DC.

## 5 Configuring the Receiver: Keypad, Indicator LEDs, and Display





The P5 GNSS reference receiver features a front panel user interface with a keypad, four indicator LEDs, and a two-line alphanumeric display. This interface enables the user to configure many of the receiver's features without using an external controller or computer.

### 5.1 Button Functions

Use the buttons on the front panel to turn on or turn off the receiver and to check or change the receiver settings.

Button	Name	Function
	Power	<p>Turn on or turn off the receiver.</p> <p>When the receiver is only powered by internal battery:</p> <p>To turn on the receiver, press and hold for 3 seconds.</p> <p>To turn off the receiver, press and hold for 2 seconds.</p> <p>When the receiver is powered by external power supply:</p> <p>The receiver will be on with power.</p> <p>The receiver will be turned off by removing the power supply from the CHCNAV cable.</p>
	Escape	Return to the previous screen or cancel changes the user makes on a screen.
	OK	Advance to the next screen or accept changes the user make on a screen.
	Up	Move the cursor between multiple fields on a screen or make changes.
	Down	Move the cursor between multiple fields on a screen or make changes.
	Left	Move the cursor between characters in an editable field.
	Right	Move the cursor between characters in an editable field.

## 5.2 Indicator LEDs

Indicator LEDs	Name	Color	Descriptions
	Power LED	Green/ Red	The indicator to show whether GNSS is on or off.  Green: The receiver operates in the absence of a power supply. Yellow-green: the status of charging and normally operating. Red: Not booting and the status of charging.
	Satellites LED	Green	Shows the number of satellites that the receiver has tracked. When the receiver is searching satellites, the green LED flashes once every 5 seconds.  When the receiver has tracked N satellites, the green LED will flash N times every 5 seconds.
	Correction LED	Yellow/ Yellow-green	Indicates whether the receiver is transmitting/receiving differential data. The yellow LED flashes once per second when  As a Base station: successfully transmitting differential data. As a Rover station: indicates single or float status The green LED flashes once per second when  As a Rover station: indicates fix status
	Network LED	Yellow	Indicates whether the receiver connects to the network.  Indicates the receiver connects to network When the LED is on, conversely, the receiver does not.



## 5.3 Home Screen

The Home screen shows:

- The name of the product.
- The position solution.
- The number of satellites being tracked.

As a power-saving feature, the front panel goes dark after a short period of inactivity. If the display is not lit and the receiver is on, press ANY BUTTON to reactivate the display.



## 5.4 Status Screens









To review the receiver's current settings in the status screens, press  or  on the front panel. The status screens show the following information:

- Current Longitude
- Current Latitude
- Current Height
- Marker name
- Marker number
- Net State
- ETH Mode
- A current IP address (editable)
- Current IP mask (editable)
- Current Gateway (editable)
- Current DNS Server (editable)
- Current HTTP port (editable)
- MAC Address
- WI-FI AP
- Set WI-FI-AP
- The internal battery power remaining
- Charging State

- Battery Temperature
- Internal Temperature
- Environment Temperature
- Internal storage memory remaining
- Receiver hardware version and software version
- Firmware Version
- Receiver serial number and part number
- Resume

## 5.5 Setting Up the Receiver as Part of An Ethernet Configuration

Use the keypad to set up the receiver as part of an Ethernet configuration. Press  or  to move between different status screens, and then press  to enter the edit mode.

- (1) Turn on the receiver by pressing the  button or connect the receiver to the external power supply.
- (2) Press  or  to move to **IP Addr** status screen.
- (3) Press  to edit IP address.
- (4) Press  or  to select the character to edit and then press  or  to change it.
- (5) When finished, press , and then the “Setting Success” message will appear on display.
- (6) Follow the **step 2** to **step 5** to edit IP mask, gateway, DNS server and HTTP port in the **IP MASK**, **Gateway**, **DNS Server** and **HTTP PORT** status screen, respectively.

# 6 Configuring the Receiver: Other Than Keypad and Display

The user can configure the P5 GNSS reference receiver to perform a wide variety of functions. This chapter describes the configuration methods other than the front panel display and explains when and why each method is used.

## 6.1 Configuring the Ethernet Settings

The receiver Ethernet port connects to an Ethernet network, through which the user can access, configure, and monitor the receiver. No serial cable connection to the receiver is necessary.

The receiver has the following Ethernet settings:

- IP address
- IP mask
- Gateway
- DNS server
- HTTP port

The default setting for the HTTP port is 80: This port is not assigned by the network. HTTP port 80 is the standard port for web servers and enables the user to connect to the receiver by entering only the receiver's IP address (check the information from the front panel) in a web browser.

For example, using port 80: **http://192.168.32.132**

If the receiver is set to use a port other than 80, the user must enter the IP address followed by the port number in a web browser.

For example, port 9971: **http://192.168.32.132:9971**

Users can configure the Ethernet settings through the front panel (see 5.4. Setting up the receiver as part of an Ethernet configuration) and a web server. To use a web server, the user must connect the receiver to a network and conduct a valid Ethernet configuration.

**Notes:** The receiver should be configured the Ethernet settings through the front panel for its first connection to the Internet.

## 6.2 Configuring through A Web Browser

Recommended browsers:

- Google Chrome
- Microsoft Internet Explorer® version 10, or higher
- Apple Safari

To connect to the receiver through a web browser:

(1) Enter the IP address of the receiver into the address bar of the web browser:

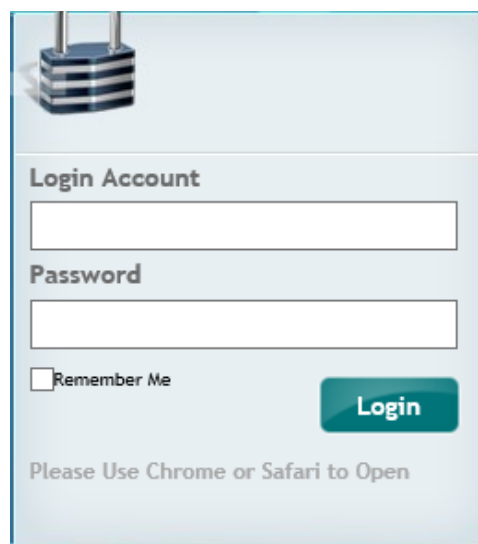

(2) The web browser prompts the user to enter a username and password:

A screenshot of a login form. At the top left is a padlock icon. Below it is the title "Login Account". There are two input fields: the first is for the "Login Account" and the second is for the "Password". Below the password field is a checkbox labeled "Remember Me". To the right of the checkbox is a green "Login" button. At the bottom of the form, there is a message: "Please Use Chrome or Safari to Open".

The default login account for the receiver is:

- a) Login Account: **admin**
- b) Password: **password**

**Notes:** Check the [remember me] checkbox, and then the browser will remember the Login Account and Password the user entered for the next time the user enters this login screen.

(3) Once the user logs in, the web page appears as follows:

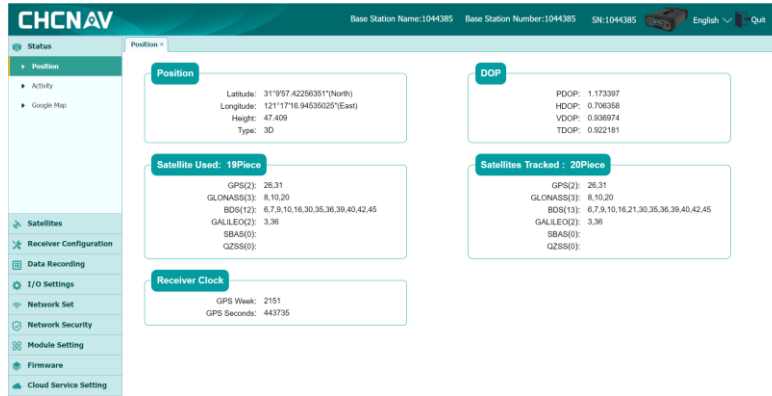

## 6.2.1 Changing the Settings

The web interface shows the configuration menus on the left of the browser window, and the setting on the right. Each configuration menu contains the related submenus to configure the receiver and monitor receiver performance.

This section describes each configuration menu.

To view the web interface in another language, select the corresponding language name from the drop-down list in the upper right corner of the interface.

Currently, three languages are available:

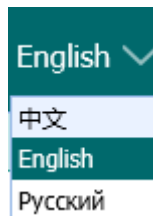

### 6.2.1.1 Status Menu

This menu provides a quick link to review the receiver's position information, satellites tracked, runtime, current data log status, current outputs, available memory, etc.

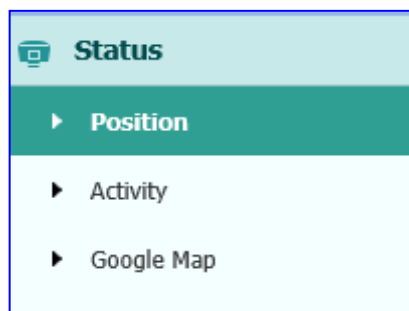

## (1) Position

This page shows the relevant position information about the receiver's position solution which including the position, DOP values, satellites used and tracked, and the receiver clock information.

**Position**

Latitude: 31°58.71924095'(North)  
Longitude: 121°17'19.11270093'(East)  
Height: 34.881  
Type: 3D

**DOP**

PDOP: 1.114537  
HDOP: 0.487425  
VDOP: 1.002301  
TDOP: 0.651936

**Satellite Used: 29Piece**

GPS(7): 5,21,18,20,13,15,24  
GLONASS(7): 5,15,20,4,13,3,19  
BDS(10): 3,1,8,4,2,7,9,13,5,6  
GALILEO(5): 26,7,8,30,2  
SBAS(0):

**Satellites Tracked: 29Piece**

GPS(7): 5,21,18,20,13,15,24  
GLONASS(7): 5,15,20,4,13,3,19  
BDS(10): 3,1,8,4,2,7,9,13,5,6  
GALILEO(5): 26,7,8,30,2  
SBAS(0):

**Receiver Clock**

GPS Week: 1970  
GPS Seconds: 291000

## (2) Activity

Lists several important items to help the user understand how the receiver is being used and its current operating condition. Items include the identities of currently tracked satellites, internal and external storage usage rate. With this information, it is easy to tell which functions the receiver is performing:

**Satellites Track: 32Piece**

GPS(10): 30,18,5,15,20,24,29,13,2,21  
GLONASS(6): 21,4,15,5,19,20  
BDS(11): 1,2,7,4,3,14,13,11,9,8,6  
GALILEO(5): 24,5,3,22,9  
SBAS(0):

UTC Time: 2017-10-12 08:04:57 (UTC)  
Operation Duration: 00-00-00 05:24:39

Internal Storage:  400MB/29767MB  
External Storage:  Not Connected

Operating temperature: 52°C  
Environment Temperature: 36°C

Outer Power: Connected  
Charge state: Charging  
Current Capacity:   
Battery temperature: 32°C

## (3) Google map

Tap this submenu to show the location of the receiver on Google map.

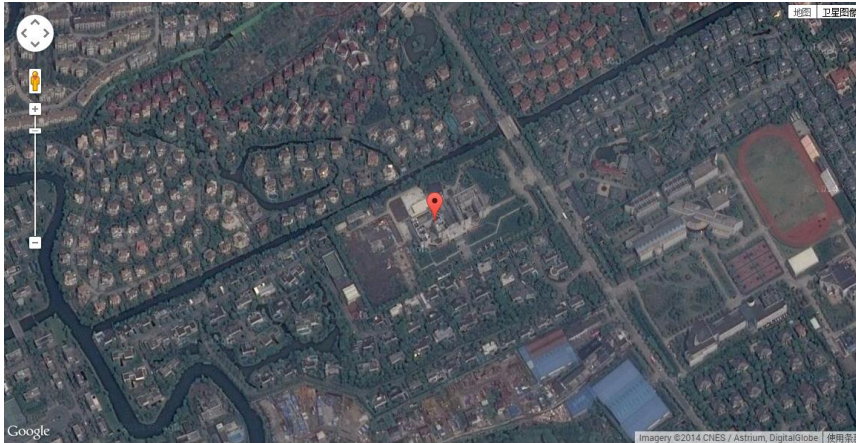

### 6.2.1.2 Satellites Menu

Use the Satellites menu to view satellite tracking details and enable/disable GPS, SBAS, GLONASS, BDS and Galileo constellations. These menus include tabular and graphical displays to provide all required information on satellite tracking status.

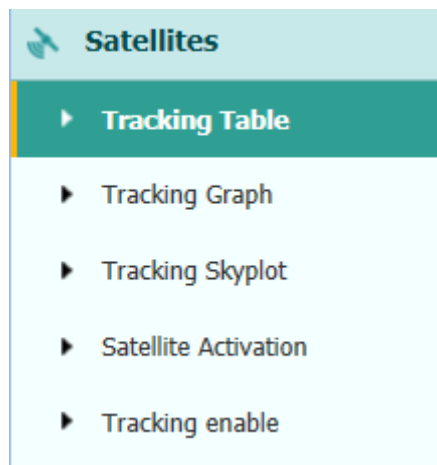

#### (1) Tracking Table

Provides the status of satellites tracked in general, such as the satellite ID, satellite type, attitude angle, azimuth angle, L1/B1/E1 SNR, L2/B2/E5a SNR, L5/B3/E5b SNR, B1c/E5 SNR, B2a/E6 SNR, B2b SNR and enable/disable status of each one.

All  GPS  GLONASS  BDS  GALILEO  SBAS  QZSS

SV	Type	Elevation Ang	Azimuth Ang	L1/B1/E1 SNR	L2/B2/E5a SN	L5/B3/E5b SN	B1c/E5 SNR	B2a/E6 SNR	B2b SNR	Enable/Disable
4	GPS	52	260	47.030	46.590	37.210	0.000	0.000	0.000	Yes
8	GPS	38	212	44.250	44.050	36.460	0.000	0.000	0.000	Yes
16	GPS	57	10	48.790	43.740	0.000	0.000	0.000	0.000	Yes
18	GPS	14	60	38.170	40.370	31.390	0.000	0.000	0.000	Yes
26	GPS	41	48	45.940	45.570	37.650	0.000	0.000	0.000	Yes
31	GPS	28	115	44.740	41.810	0.000	0.000	0.000	0.000	Yes
1	GLONASS	26	271	45.470	37.290	0.000	0.000	0.000	0.000	Yes
2	GLONASS	6	330	46.580	37.240	0.000	0.000	0.000	0.000	Yes
8	GLONASS	19	224	40.890	40.740	0.000	0.000	0.000	0.000	Yes
9	GLONASS	11	88	45.790	39.940	0.000	0.000	0.000	0.000	Yes
10	GLONASS	44	46	53.290	0.000	0.000	0.000	0.000	0.000	Yes
20	GLONASS	45	59	39.140	43.830	0.000	0.000	0.000	0.000	Yes
1	BDS	46	139	45.700	46.150	44.200	0.000	0.000	0.000	Yes
3	BDS	50	199	45.860	45.340	43.780	0.000	0.000	0.000	Yes
6	BDS	56	185	44.860	46.610	45.640	0.000	0.000	0.000	Yes

## (2) Tracking Graph

The following figure is an example of satellite track diagram page. Users can determine the satellite types and the corresponding SNR to be displayed in any combination.

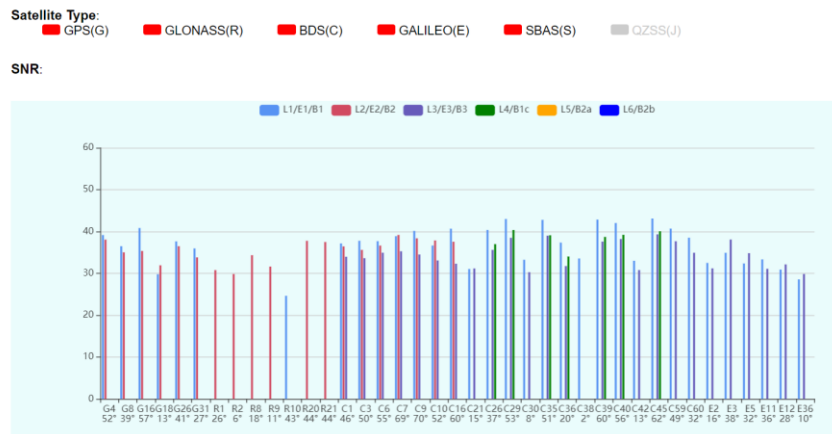

## (3) Tracking SkyPlot

The following figure is an example of Skyplot page.

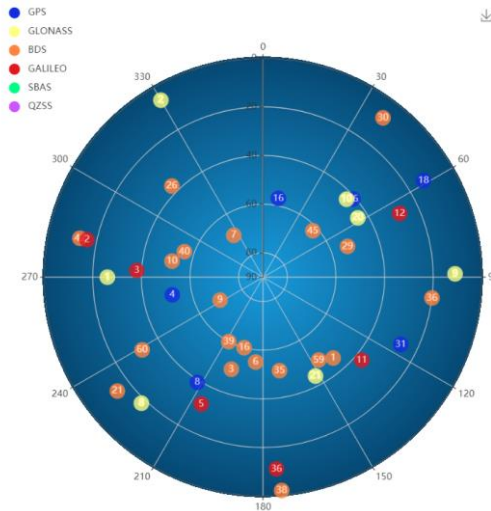

#### (4) Tracking Activation

In this submenu, users can enable/disable GPS, SBAS, GLONASS, BDS and Galileo constellations.

GPS   GLONASS   BDS   GALILEO   SBAS   QZSS			
<input type="checkbox"/> Select All <input type="checkbox"/> Unselect All <input type="checkbox"/> Confirm <input type="checkbox"/> Enable All <input type="checkbox"/> Disable All			
Satellite Id	Enable	Satellite Id	Enable
1	<input checked="" type="checkbox"/>	2	<input checked="" type="checkbox"/>
3	<input checked="" type="checkbox"/>	4	<input checked="" type="checkbox"/>
5	<input checked="" type="checkbox"/>	6	<input checked="" type="checkbox"/>
7	<input checked="" type="checkbox"/>	8	<input checked="" type="checkbox"/>
9	<input checked="" type="checkbox"/>	10	<input checked="" type="checkbox"/>
11	<input checked="" type="checkbox"/>	12	<input checked="" type="checkbox"/>
13	<input checked="" type="checkbox"/>	14	<input checked="" type="checkbox"/>
15	<input checked="" type="checkbox"/>	16	<input checked="" type="checkbox"/>
17	<input checked="" type="checkbox"/>	18	<input checked="" type="checkbox"/>
19	<input checked="" type="checkbox"/>	20	<input checked="" type="checkbox"/>
21	<input checked="" type="checkbox"/>	22	<input checked="" type="checkbox"/>
23	<input checked="" type="checkbox"/>	24	<input checked="" type="checkbox"/>
25	<input checked="" type="checkbox"/>	26	<input checked="" type="checkbox"/>
27	<input checked="" type="checkbox"/>	28	<input checked="" type="checkbox"/>
29	<input checked="" type="checkbox"/>	30	<input checked="" type="checkbox"/>

#### (5) Tracking enable

In this submenu, users can enable/disable the signals of each constellation. Please click [Confirm] button after the users finish the collection.

Type	single	Enable
GPS	L1	<input checked="" type="checkbox"/>
GPS	L2P	<input checked="" type="checkbox"/>
GPS	L2C	<input checked="" type="checkbox"/>
GPS	L5	<input checked="" type="checkbox"/>
GLONASS	R1	<input checked="" type="checkbox"/>
GLONASS	R2	<input checked="" type="checkbox"/>
GALILEO	E1	<input checked="" type="checkbox"/>
GALILEO	E5a	<input checked="" type="checkbox"/>
GALILEO	E5b	<input checked="" type="checkbox"/>
BeiDou	B1	<input checked="" type="checkbox"/>
BeiDou	B1C	<input checked="" type="checkbox"/>
BeiDou	B2	<input checked="" type="checkbox"/>
BeiDou	B2A	<input checked="" type="checkbox"/>
BeiDou	B3	<input checked="" type="checkbox"/>
QZSS	Q1	<input checked="" type="checkbox"/>
QZSS	Q2	<input checked="" type="checkbox"/>
QZSS	Q5	<input checked="" type="checkbox"/>

### 6.2.1.3 Receiver Configuration Menu

Use this menu to configure settings such as the antenna type and height, elevation mask and PDOP setting, the reference station coordinates, receiver resetting and web interface language:

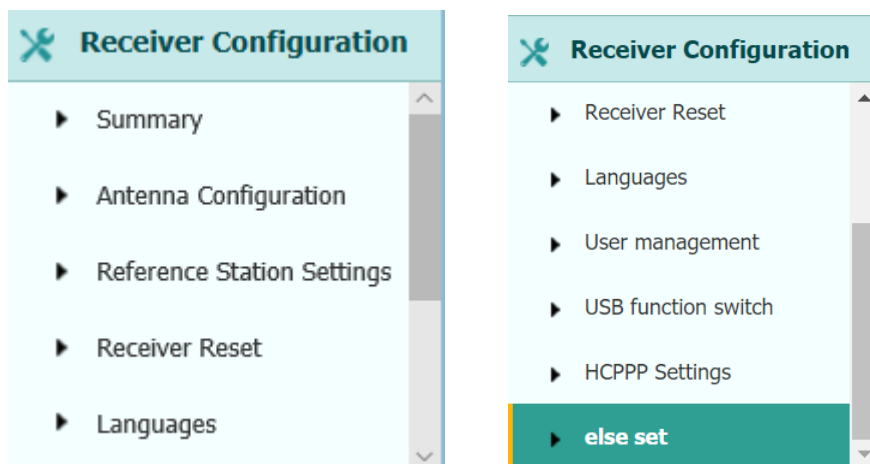

#### (1) Summary

This submenu shows the receiver information and reference station information, including antenna related information, elevation mask angle, reference station work-mode and position, etc.

### Receiver Info

Antenna Type:  
Antenna Number: 1020898  
Measure Way: Antenna Phase Center  
Antenna Height: 2.0000(Meter)  
Elevation Mask: 0  
PDOP Mask: 6

### Reference Station Info

Reference Station Mode: Auto Rover  
Reference Latitude: 0°0'0.00000000"(South)  
Reference Longitude: 0°0'0.00000000"(West)  
Reference Height: 0.0000

## (2) Antenna configuration

Use this screen to configure all the items relating to the GNSS antenna. The user must enter the correct values for all antenna-related fields, as the choices the user makes significantly affect the accuracy of logged data and broadcast RTK correctors:

### Antenna Configuration

Measure Way: Vertical Height  
Antenna manufacturer: CHCNav  
Antenna Type: CHCAT312 NONE  
Antenna Number: 1044385  
Antenna Height: 0.0000 (Meter)  
Elevation Mask: 0  
PDOP Mask: 6

Save

## (3) Reference Station Settings

Use this screen to configure settings such as the station coordinates. The user must enter accurate information in these fields, as this data significantly affects the accuracy of logged data files and broadcast RTK correctors.

Reference Station Mode:

Base Station Name:

Base Station Number:

Reference Latitude: ° ' ''  N  S

Reference Longitude: ° ' ''  E  W

Reference Height:

**Sample for Average**

Positioning Constraint:  Single Solution Coordinates  Fixed Solution Coordinates

Sampling Amount:

Coordinates transfer threshold value(Meter):

**Reference Station Settings**

Reference Station Mode:

Base Station Name:

Base Station Number:

Reference Latitude: ° ' ''  N  S

Reference Longitude: ° ' ''  E  W

Reference Height:

**Sample for Average**

Positioning Constraint:  Single Solution Coordinates  Fixed Solution Coordinates

Sampling Amount:

**For Reference Station Mode:**

There are three available options: Auto Rover, Auto Base, and Manual Base.

- **Auto Rover:** The receiver will serve as Rover after the user restarts the receiver each time.
- **Auto Base:** The receiver will serve as Base after the restart, and then broadcast RTK correctors based on coordinates obtained through single-point positioning automatically.

- **Manual Base:** The receiver will serve as Base after the restart, and then broadcast RTK correctors based on **the** coordinates before power off.

For **Reference Latitude** and **Reference Longitude**:

There are mainly three methods to enter the reference coordinates and shown as follows:

- **Acquire Current Position:** Click this button to acquire current position obtained through single-point positioning automatically.
- **Manual Input:** Manually input the known coordinates.
- **From CORS:** After logging in CORS, the receiver will obtain a coordinate based the configurations at the **Sample for Average** field. (See 6.2.1.5. I/O Settings menu for more details about logging in CORS.)

For **Sample for Average**:

If the users chose to get the location coordinate from CORS, the users could determine the positioning limit and sampling amount. The positioning limit falls into two types:

- **Single Solution Coordinates:** Collect the coordinates of receiver obtained through single-point positioning.
- **Fixed Solution Coordinates:** Only collect coordinates of the receiver based on fix solution.

After the configuration of positioning limit and sampling amount, click  to carry out sampling and to average → the result will be served as the coordinates of the current position.

Also, users can click  to save the current settings.

(4) Receiver Reset

Use this screen to completely or partially reset the receiver:

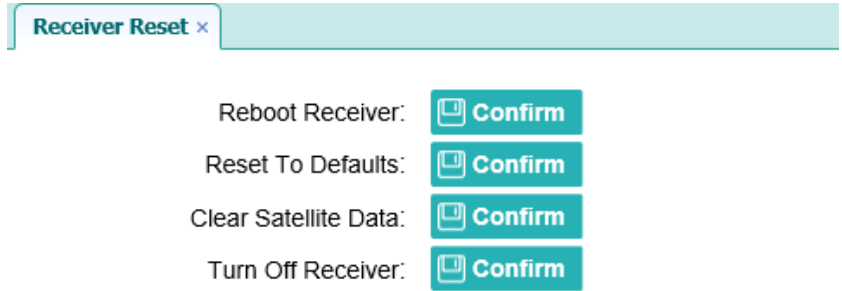

### (5) Languages

Use this screen to select the web interface language:



### (6) User management

Use this screen to edit user management:

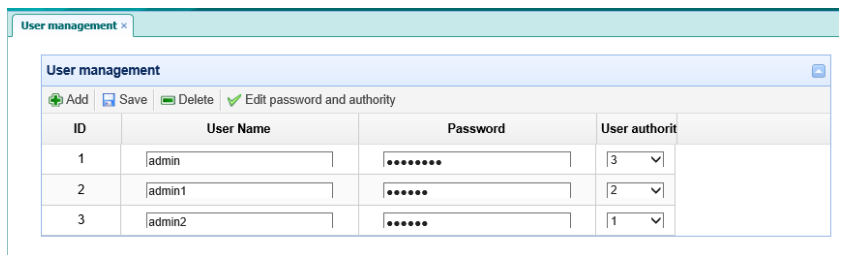

### (7) USB function Switch

Use this screen to switch USB function:

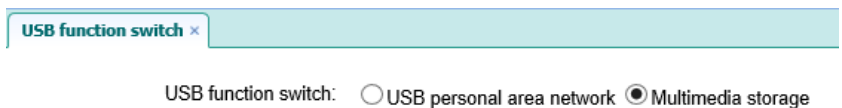

### (8) HCPPP Settings

Use this screen to set HCPPP:

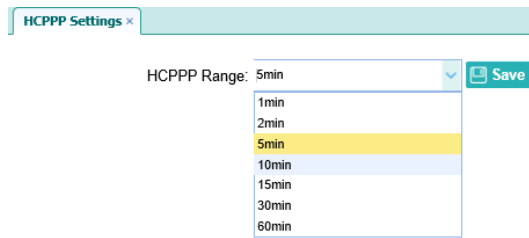

(9) else settings

Use this screen to set :1PPS, clockswitch, psrsmooth, simulator.

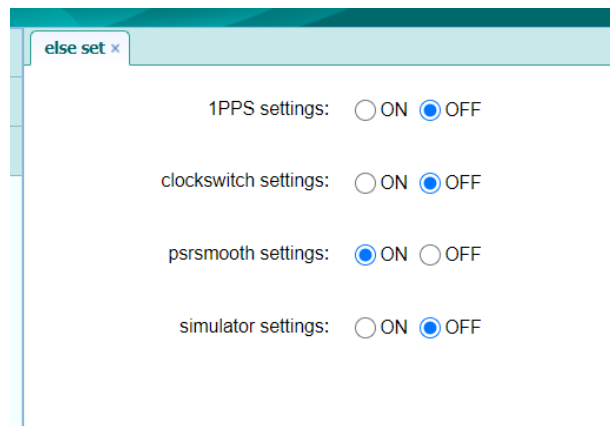

### 6.2.1.4 Data Recording Menu

Use the Data Logging menu to set up the receiver to log static GNSS data and to view the logging settings. The user can configure settings such as observable rate, recording rate, continuous logging limit, and whether to auto delete old files if memory is low. This menu also provides the controls for the FTP push feature:

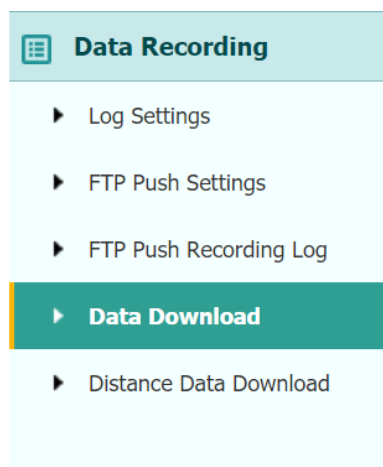

## (1) Log Settings

This page shows the data logging status, internal and external storage usage and data logging status of each storage thread. Also, users can configure the data logging settings for each storage thread, including recording name, saving location, storage limit, store formats, start time, etc.

Log Settings

Store Info			
	Position	Total Storage	Storage Available
1	Internal Storage	29767MB	29373MB
2	External Storage	0MB	0MB

Attention: Total assigned storage size of 8 threads should be less than 27GB. It will stop recording when the storage is full.

Record Info						
Recording Nur	File Name	Activate	Log Status	Setting Parameter	Switch	Clear Data
1	record1	Yes	Recording	Modify Delete	ON OFF	Clear
2	record2	No	Not Recording	Modify Delete	ON OFF	Clear
3	record3	No	Not Recording	Modify Delete	ON OFF	Clear
4	record4	No	Not Recording	Modify Delete	ON OFF	Clear
5	record5	No	Not Recording	Modify Delete	ON OFF	Clear
6	record6	No	Not Recording	Modify Delete	ON OFF	Clear
7	record7	No	Not Recording	Modify Delete	ON OFF	Clear
8	record8	No	Not Recording	Modify Delete	ON OFF	Clear

To open or close all the storage threads, click the [ON] or [OFF] button at the Switch field.

**Notes:** The [ON] and [OFF] button to the right of Log Status field are the Master Log Switch. Every storage thread can log data only when the Master Log Switch is ON. And users can edit the settings of storage threads only when the Master Log Switch is OFF.

To edit the settings of each storage thread, click the [Modify] button at the right of the required storage thread, and then the Recording Edit screen appears:

Recording Edit

Auto Record:  Yes  No

Sample Interval: 5s

Elevation Mask: 0 (\*)

Duration Time: 1440 (Minute)

Site Name: 1020898

Antenna Height: 0.0000

Measure Way: Vertical Height

Storage Format: HCN

Rinex Store: OFF

Advanced

Store Location: Internal Storage

Assigned Storage: 1000 (MB)

Observer: CHC

Observe Agency: CHC

FTP Push:  Close  
 1.ftp server 1  
 2.ftp server 2  
 3.ftp server 3

Start Date:  Yes  No

Apply Time:  Yes  No

Integral Point Store:  Yes  No

Circulating Memory:  Yes  No



Single Collect:  Yes  No

Set up a period and record it once. the next record will automatically start following the previous one if user chooses negative

Save Back

In this screen, the user can set all data logging parameters, and determine whether the recording files will be affected by the FTP Push. The main parameters are as follows:

- a) Auto Record: Select “Yes” or “No” to determine whether to log data when the Master Log Switch is ON.
- b) Sample Interval: Select the observable rate from the dropdown list.
- c) Store Location: Determine whether to store in internal storage or external storage.
- d) Start Date: Set the start time of data log in UTC. Select “Yes” or “No” option below to determine whether to start logging from the set time.
- e) Duration Time: Set the time interval of recording.
- f) Storage: Set the storage limit of this thread.
- g) Circulating Memory: Select “Yes” or “No” to determine whether to auto delete old files if the storage space is full.
- h) Storage Format: The default format of recording files is HCN.
- i) FTP Push: Decide whether to push the stored files to the FTP server of the user’s choice.

Click  to save the settings and back to the Log Settings screen. Also, users can click  to abandon the changed settings and back to Log Settings screen.

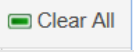
**Notes:** To delete the record data, the user can remove all the record data by the total button  and clear all accounts. Also, the user can delete each record data by the clear button under the selected thread.

To delete the recorded files of **ANY** storage thread, click the  to the right of the required storage thread.

To delete the recorded files of **ALL** storage threads, click **[Clear All]** button.

## (2) FTP Push Settings

Use this screen to configure the receiver to push stored files to the FTP server of the user’s choice. Only files that are configured to use FTP push are transmitted. Click

**Modify** to the right of the required FTP server, and the FTP Push Settings screen appears:

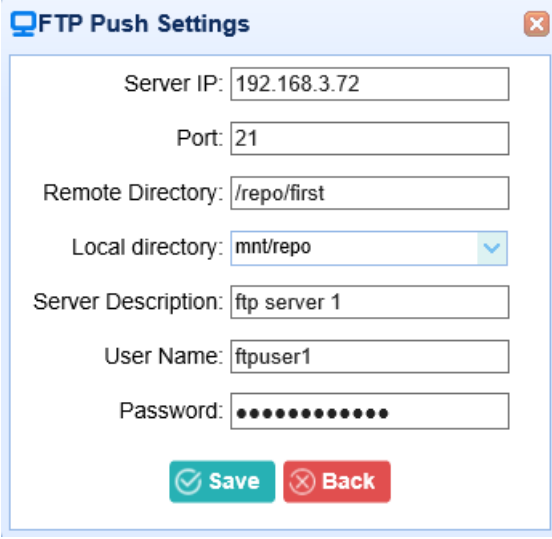

The screenshot shows a dialog box titled "FTP Push Settings" with a close button in the top right corner. The dialog contains the following fields and controls:

- Server IP: 192.168.3.72
- Port: 21
- Remote Directory: /repo/first
- Local directory: mnt/repo (with a dropdown arrow)
- Server Description: ftp server 1
- User Name: ftpuser1
- Password: [masked with 10 dots]

At the bottom of the dialog, there are two buttons: a green "Save" button with a checkmark icon and a red "Back" button with an 'X' icon.

### (3) FTP Push Recording

Shows the related information about the recorded files that will be pushed. And users can click **[Clear FTP Push Log]** in the upper right corner to clear the status of FTP Push operations.

### (4) Data Download

In this submenu, users can download the data files that recorded in the internal storage through the internal FTP site. Also, the user can directly download the static data through file explorer.

#### a) Use web data download submenu:

Click this submenu, and then the login dialogue box will prompt the user to enter a username and password:

**Authentication required**

ftp://192.168.32.161  
Your connection to this site is not private

Username

Password





The default login account for the internal FTP site is:

Username: ftp

Password: ftp

Click the directory named **logs/** to view and download the files currently stored on the receiver:



## Index of /

	Name	Size	Date Modified
	<a href="#">FSCK0000.REC</a>	16.0 kB	1/1/80, 8:00:00 AM
	<a href="#">FSCK0001.REC</a>	16.0 kB	1/1/80, 8:00:00 AM
	<a href="#">logs/</a>		3/27/18, 10:00:00 AM
	<a href="#">repo/</a>		4/3/18, 5:39:00 PM
	<a href="#">test.log</a>	4.0 MB	3/27/18, 7:44:00 PM

To find the file need to be downloaded, click the name of storage folder (“logs\_” plus with the number of the storage thread) → the date of the file that be recorded → the format of the file → the name of the target file.

## Index of /logs/logs\_1/

 [\[parent directory\]](#)

	Name	Size	Date Modified
	<a href="#">hcn/</a>		4/2/18, 5:18:00 PM
	<a href="#">rinex/</a>		4/2/18, 5:18:00 PM

To download a file, left-click the name of the target file → download the file according to the prompts.

## b) Use File Explorer

According to the IP of the P5 receiver, in the writer's case, Input **ftp://192.168.32.161/** into the File Explorer. Press Enter and the user can download the data from the logs folder after successful login the internal FTP site (same account as given above):

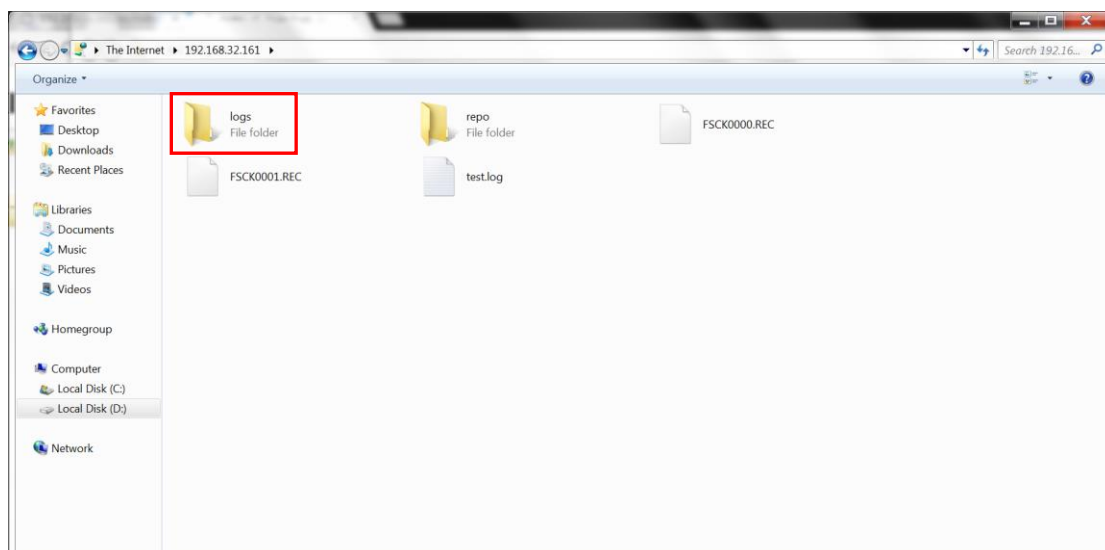
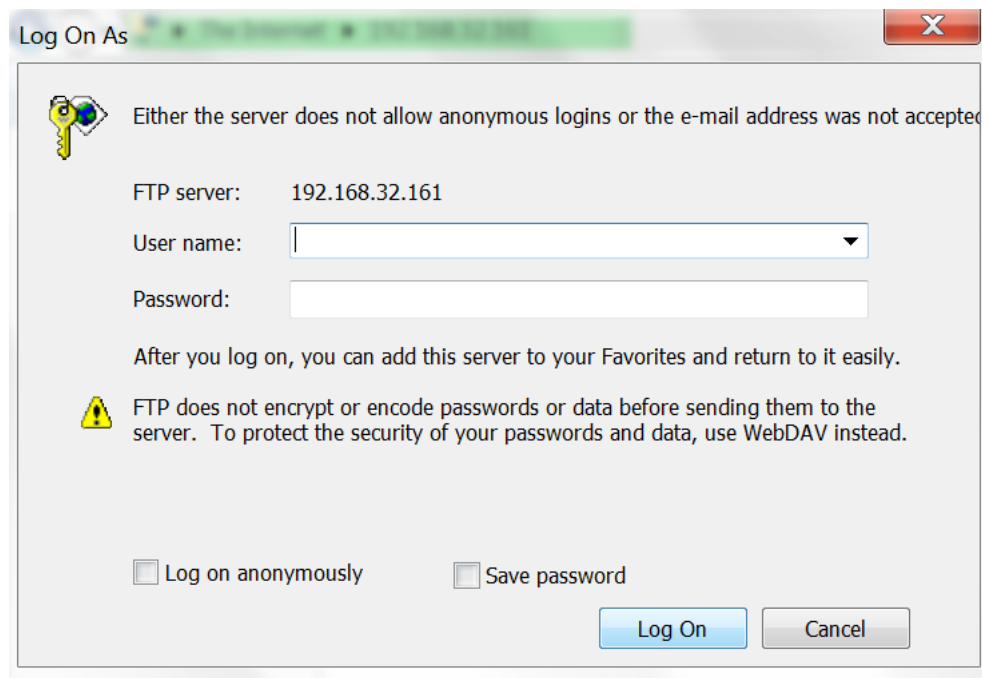

The path of the static data is inside the “logs” folder, the same with the downloading path from the website.

## (5) Distance Download

Use this function to login data after you set port forwarding.

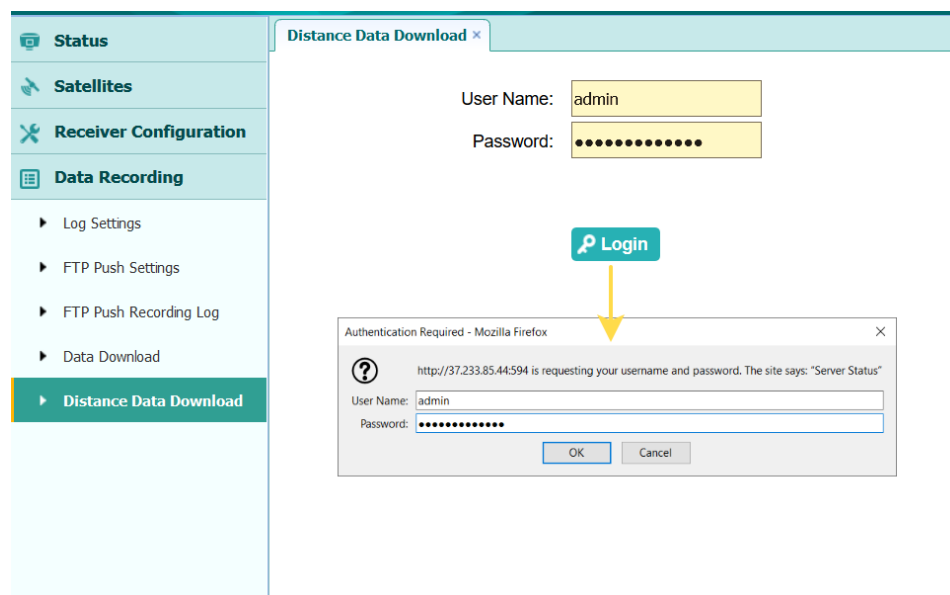

### 6.2.1.5 I/O Settings Menu

Use the I/O Settings menu to set up all receiver outputs and inputs. The receiver can output CMR, RTCM, Raw data, Ephemeris data, GPGGA, GPGSV, on TCP/IP, UDP, serial port, or Bluetooth ports.

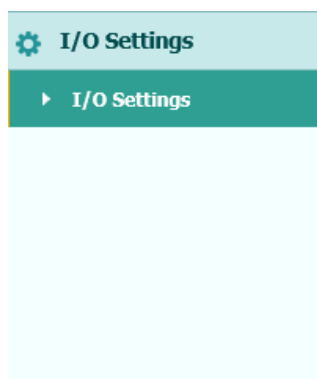

The following figure shows an example of the screen that appears when the user selects this submenu.

I/O Settings						
	Type	Summary	Output	Connection Status	Modify	
1	RTK Client	211.144.118.5:2102	---	Unconnected	Connect	Disconnecting
2	TCP/UDP_Client1/Ntrip Server1	192.168.3.18:9900	---	Unconnected	Connect	Disconnecting
3	TCP/UDP_Client2/Ntrip Server2	192.168.3.18:9901	---	Unconnected	Connect	Disconnecting
4	TCP/UDP_Client3/Ntrip Server3	192.168.3.18:9902	---	Unconnected	Connect	Disconnecting
5	TCP/UDP_Client4/Ntrip Server4	192.168.3.18:9903	---	Unconnected	Connect	Disconnecting
6	TCP/UDP_Client5/Ntrip Server5	192.168.3.18:9904	---	Unconnected	Connect	Disconnecting
7	TCP/UDP_Client6/Ntrip Server6	192.168.3.18:9905	---	Unconnected	Connect	Disconnecting
8	TCP Server/NTRIP Caster1	9901	Physical Info:30s,Differential Ephemeris Auto,Differential Data RTCM3.3	Opened	Connect	Disconnecting
9	TCP Server/NTRIP Caster2	9902	---	Closed	Connect	Disconnecting
10	TCP Server/NTRIP Caster3	9903	---	Closed	Connect	Disconnecting
11	TCP Server/NTRIP Caster4	9904	---	Closed	Connect	Disconnecting
12	Serial Port(DB9)	9600	---	---	Settings	
13	Serial Port(COM2)	9600	---	---	Settings	
14						

In this submenu, users can configure 4 types of input and output settings.

### (1) RTK Client

After configuring the settings of RTK client, users can log on CORS or APIS. Click the **[Connect]** button to the right → the **I/O Settings** screen will appear → choose one of the connection protocols among the NTRIP, APIS\_BASE, and APIS\_ROVER → configure the related parameters → click **[Confirm]** to log on CORS or APIS.

#### a) Connection Protocol: NTRIP

#### b) Connection Protocol: APIS\_BASE

The screenshot shows the 'RTK Client' dialog box. It has a title bar with a close button. The main area contains the following fields:

- Connection Protocol: A dropdown menu with 'APIS\_BASE' selected.
- Server IP: An empty text input field.
- Port: An empty text input field.
- Differential Data: A dropdown menu with 'OFF' selected.

At the bottom, there are two buttons: a green 'Confirm' button with a checkmark icon and a red 'Back' button with an 'X' icon.

c) Connection Protocol: APIS\_ROVER

The screenshot shows the 'RTK Client' dialog box. It has a title bar with a close button. The main area contains the following fields:

- Connection Protocol: A dropdown menu with 'APIS\_ROVER' selected.
- Server IP: An empty text input field.
- Port: An empty text input field.
- Base ID: A dropdown menu.

At the bottom, there are two buttons: a green 'Confirm' button with a checkmark icon and a red 'Back' button with an 'X' icon.

d) TCP/UDP Client

Click the **[Connect]** button to the right of required TCP/UDP Client → the **TCP/UDP Client** screen will appear → select the connection protocol from the dropdown list → enter the IP and Port of the target server → configure messages that the user want to output to the target server → click **[Confirm]** to save and complete the connection.

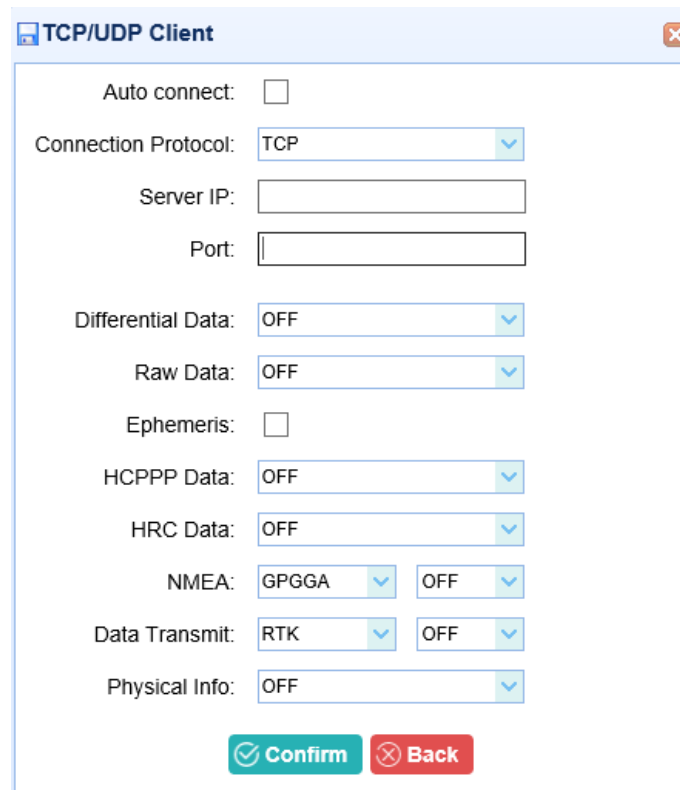

**TCP/UDP Client**

Auto connect:

Connection Protocol: TCP

Server IP:

Port:

Differential Data: OFF

Raw Data: OFF

Ephemeris:

HCPPP Data: OFF

HRC Data: OFF

NMEA: GPGGA OFF

Data Transmit: RTK OFF

Physical Info: OFF

**Notes:** If the receiver and server are under the same Local Area Network (LAN), users can use the IP address in LAN of the server with any Port. However, if the receiver and server are under the two different LAN, users should use the public IP address of the server and configure the port mapping of the server.

## (2) TCP/IP Server

Click the **[Connect]** button to the right of required TCP/IP Server → the **TCP Server/Ntrip Caster** screen will appear → select one of the connection protocols between NTRIP and TCP → configure the other related parameters → click **[Confirm]** to save the settings and open the server.

### a) Connection Protocol: NTRIP

The screenshot shows the 'TCP Server/NTRIP Caster' configuration window. The 'Auto connect' checkbox is checked. The 'Connection Protocol' dropdown is set to 'NTRIP'. Below this are input fields for 'User Name', 'Password', 'Port', and 'Source List'. Further down are dropdown menus for 'Differential Data' (OFF), 'Raw Data' (OFF), 'HCPPP Data' (OFF), 'HRC Data' (OFF), and 'Physical Info' (OFF). There are also checkboxes for 'Ephemeris' and 'Data Transmit' (RTK), and a dropdown for 'NMEA' (GPGGA) with an 'OFF' checkbox. At the bottom are 'Confirm' and 'Back' buttons.

b) Connection Protocol: TCP

The screenshot shows the 'TCP Server/NTRIP Caster' configuration window. The 'Auto connect' checkbox is checked. The 'Connection Protocol' dropdown is set to 'TCP'. Below this is an input field for 'Port'. Further down are dropdown menus for 'Differential Data' (OFF), 'Raw Data' (OFF), 'HCPPP Data' (OFF), 'HRC Data' (OFF), and 'Physical Info' (OFF). There are also checkboxes for 'Ephemeris' and 'Data Transmit' (RTK), and a dropdown for 'NMEA' (GPGGA) with an 'OFF' checkbox. At the bottom are 'Confirm' and 'Back' buttons.

(3) COM Port

Click the **[Settings]** button on the right of required COM Port row → the **Serial Port Setup** screen will appear → select Baud Rate used to transmit data → configure the messages that the user want to output through the serial port → click **[Confirm]** to save the settings and start to transmit.

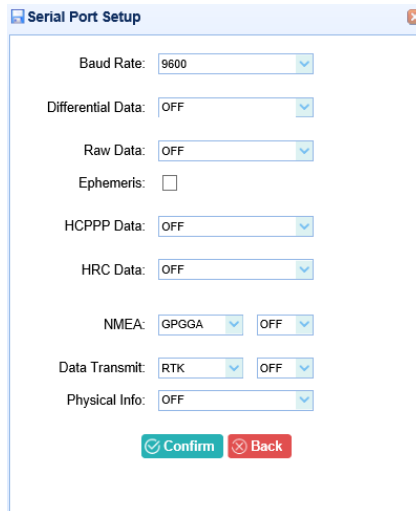

**Notes:** For the “Serial Port (DB9)”, it is compatible with connection with external meteorograph.

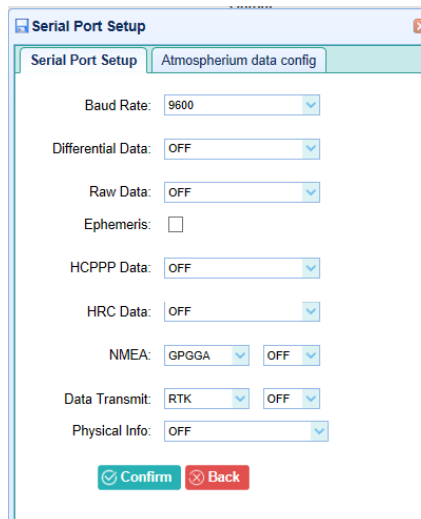

#### (4) Bluetooth

Click the **[Settings]** button on the right of Bluetooth row → the **Bluetooth Set** screen will appear → configure the messages that the user want to transmit through Bluetooth → click **[Confirm]** to save the settings and start to transmit.

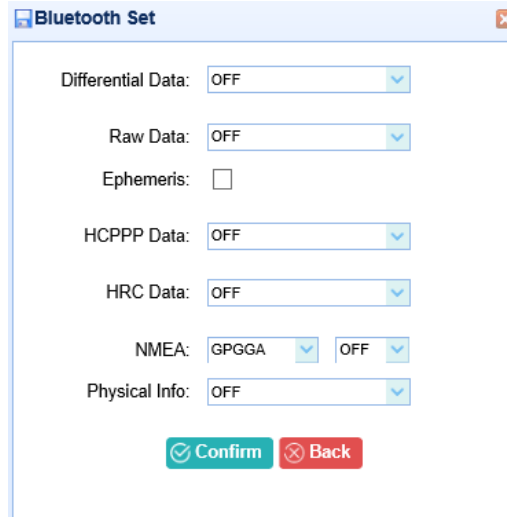

### 6.2.1.6 Network Set Menu

Use this menu to check and configure the Ethernet settings:

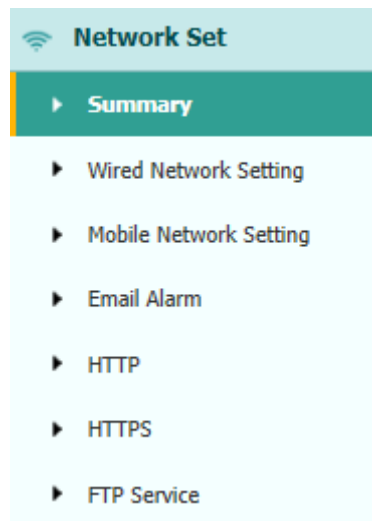

(1) Summary

The following figure shows an example of the screen that appears when the user selects this submenu:

Summary x

**Wired Network Information**

Ethernet Status: Connected  
 Ethernet IP: 192.168.32.132  
 Subnet Mask: 255.255.255.0  
 Gateway: 192.168.32.1  
 DNS Address 1: 192.168.0.5

**Mobile Network Information**

Power Status: ON  
 Network Mode/Network Model: Automatic Selection of 2G/3G  
 Network  
 Connection Protocol:  
 Signal Strength: 0(dBm)  
 SIM Status: No SIM Card  
 Dialing Status: Dialing  
 IMEI:

## (2) Wired Network Setting

Use this submenu to configure the related parameters of the Network, including static IP, subnet mask, etc.

**Wired Network Setting** x

Static IP  DHCP

**Ethernet**

IP Address:

Subnet Mask:

Gateway:

**DNS:**

DNS Address 1:

 Save

## (3) Mobile Network Setting

Use this submenu to configure the settings of the Network, then support mobile network.

**Mobile Network Setting** x

**Network Set**

GPRS Model Status: ON ON OFF

Auto Start:  Yes  No

---

Network Mode/Network Model:  Only Use The 2G Network  Only Use The 3G Network  
 Automatic Selection of 2G/3G Network

---

Dialing Status: Dialing Dial Break

Auto Connect:  Yes  No

---

APN:

Dialing String:

User Name/User Name:

Password/Password:

 Save

## (4) Email Alarm

**Email Alarm**

**TO**

Email Address 1:

Email Address 2:

Email Address 3:

**From**

Account:

Password:

Server Address:

**Email Alert**

Receiver is powered on

External power is off

Battery level is low

Flip push is failed

Receiver(license) will be expired in 7 days.

(5) HTTP

**HTTP** x

HTTP Port:

(6) HTTPS

**HTTPS** x

Enable HTTPS:  Yes  No

HTTPS Port:

(7) FTP Service

**FTP Service** x

User Name:

Password:

### 6.2.1.7 Network Security Menu

Use this menu to check and configure the Network Security.

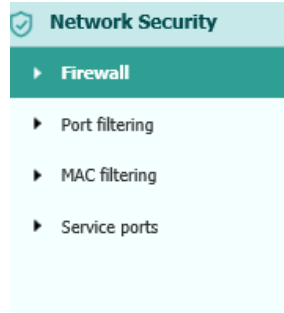

## (1) Firewall

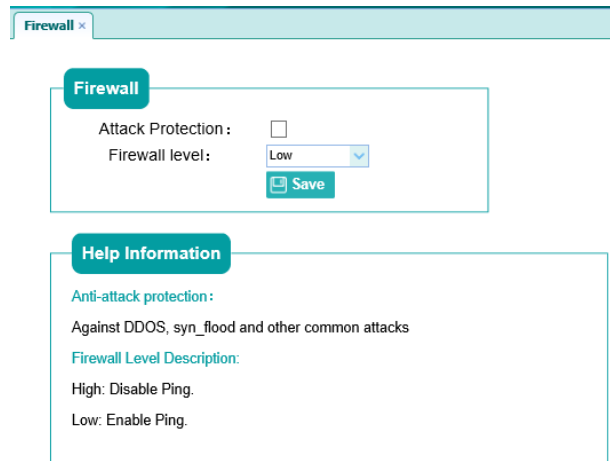

## (2) Port filtering

Use this submenu to control the access to the corresponding port of the receiver.

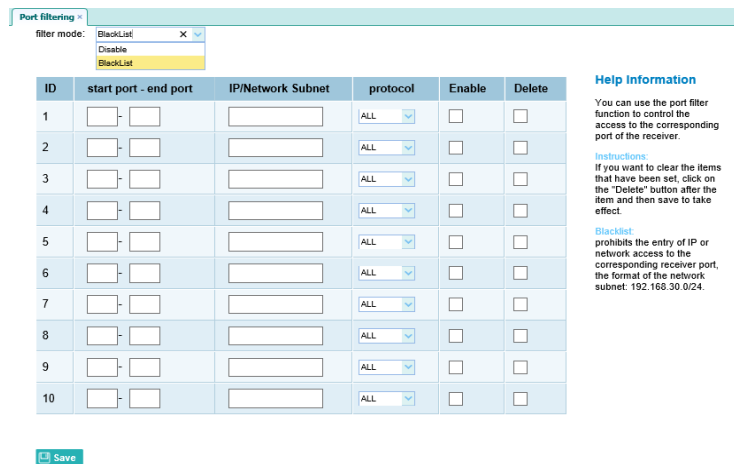

## (3) MAC filtering

Use this submenu to control the computer's access to the receiver on the LAN.

MAC filtering ×

filter mode: BlackList

ID	MAC address	Enable	Delete
1	<input type="text"/>	<input type="checkbox"/>	<input type="checkbox"/>
2	<input type="text"/>	<input type="checkbox"/>	<input type="checkbox"/>
3	<input type="text"/>	<input type="checkbox"/>	<input type="checkbox"/>
4	<input type="text"/>	<input type="checkbox"/>	<input type="checkbox"/>
5	<input type="text"/>	<input type="checkbox"/>	<input type="checkbox"/>
6	<input type="text"/>	<input type="checkbox"/>	<input type="checkbox"/>
7	<input type="text"/>	<input type="checkbox"/>	<input type="checkbox"/>
8	<input type="text"/>	<input type="checkbox"/>	<input type="checkbox"/>
9	<input type="text"/>	<input type="checkbox"/>	<input type="checkbox"/>
10	<input type="text"/>	<input type="checkbox"/>	<input type="checkbox"/>

**Help Information**

You can use the MAC address filtering function to control the computer's access to the receiver on the LAN.

**Instructions**  
If you want to clear the items that have been set, click the "Delete" button after the item and then save to take effect.

**Blacklist**  
Disables access to the receiver for MAC addresses that are enabled in the table.

#### (4) Service ports

Service ports ×

**Service ports**

- telnet
- ssh
- ftp

**Help Information**

**Enable:** Receiver starts the service

**Disable:** Receiver disables the service

### 6.2.1.8 Module Setting Menu

Use this menu to check and configure the Module settings.

 **Module Setting**

- ▶ Summary
- ▶ Wifi Settings
- ▶ Bluetooth Set

#### (1) Summary

The following figure shows an example of the screen that appears when the user selects this submenu:

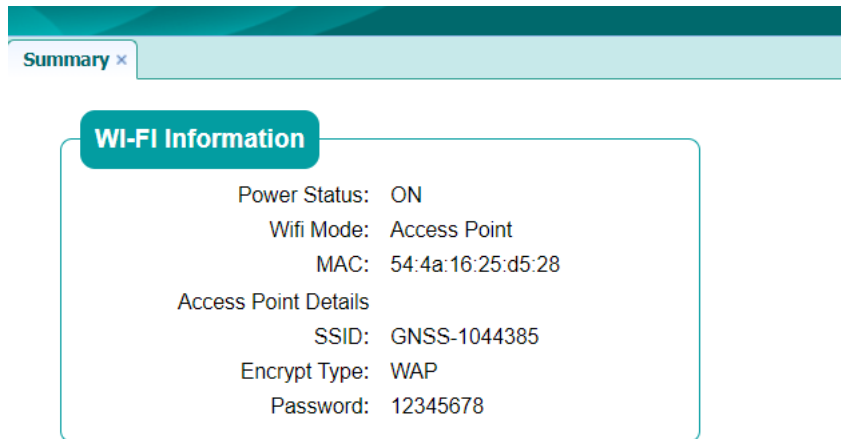

## (2) Wi-Fi Settings

Use this submenu to configure the related parameters of the Wi-Fi settings, including Wi-Fi mode, encrypt type, password, etc.

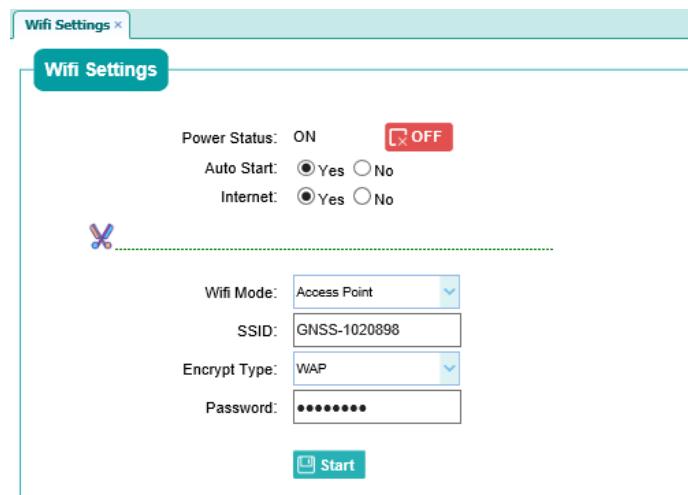

## (3) Bluetooth Settings

The following figure shows an example of the screen that appears when the user selects this submenu:

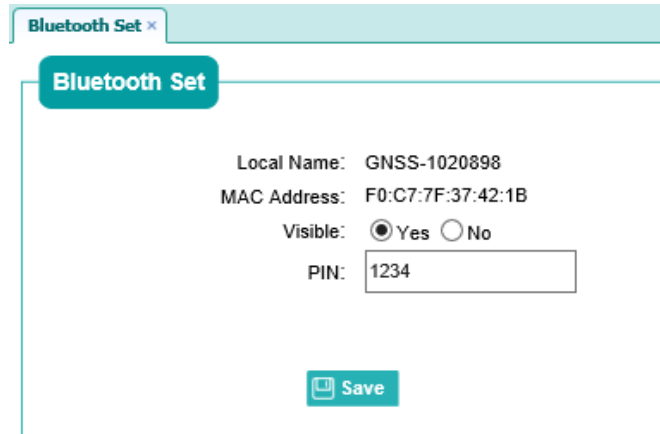

### 6.2.1.9 Firmware Menu

Use this menu to check the current firmware information, download the system log, update the receiver firmware, download or update the configuration file and register the receiver.

#### (1) Firmware Info

Use this submenu to check the current firmware information. The following figure shows an example of the firmware information.

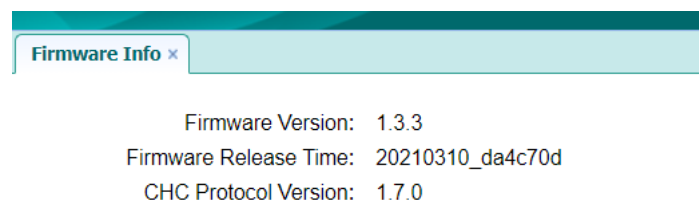

#### (2) The Hardware Version

Use this submenu to check the current hardware information. The following figure shows an example of the hardware information.

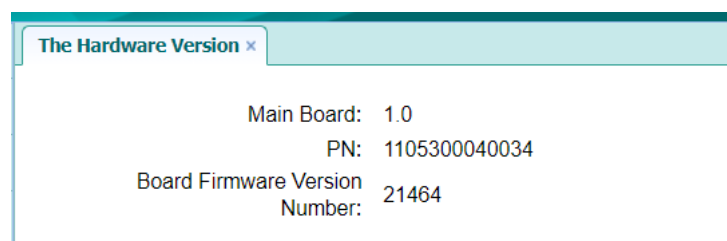

#### (3) Config File

In this submenu, users can download the configuration file by clicking [**Download**] button and determine a saving path to download the configuration file (.cfg file). Also, users can click the [**Browse**] button to locate the existing configuration file → click [**Confirm**] button to confirm the selected file and start updating.

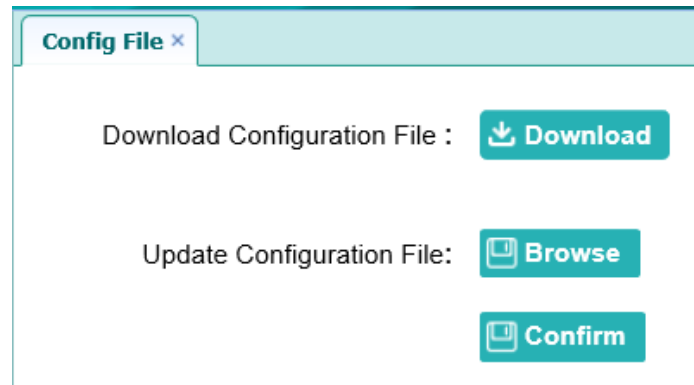

#### (4) System Log

Use this submenu to download the system log of the receiver.

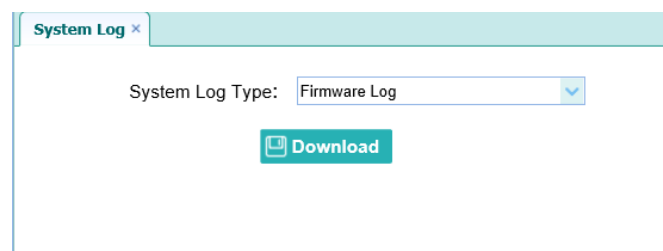

#### (5) User Log

Use this submenu to tick which logs files and downloads the user log of the receiver.

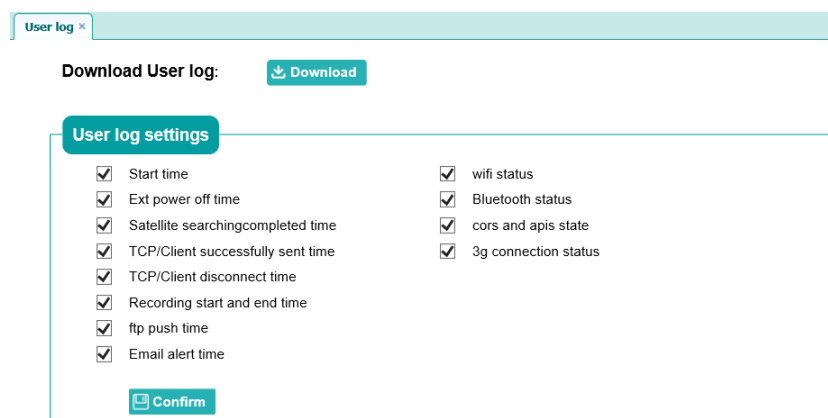

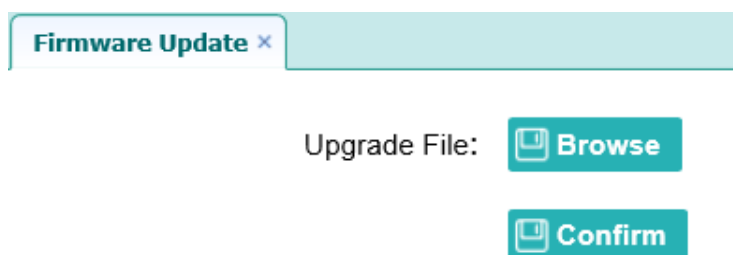

#### (6) Firmware Update

Use this submenu to load new firmware to the receiver across the network. Click the **[Browse]** button to locate the upgrade file → click **[Confirm]** button to confirm the selected upgrading file and start upgrading.



Firmware Update x

Upgrade File:  **Browse**

 **Confirm**

**Notes:** It will take about 2 or 3 minutes to complete the firmware upgrading.

### (7) Board Upgrade

Use this submenu to upgrade board. Click **[Browse]** to choose upgrade files and Click **[Confirm]** to upgrade.

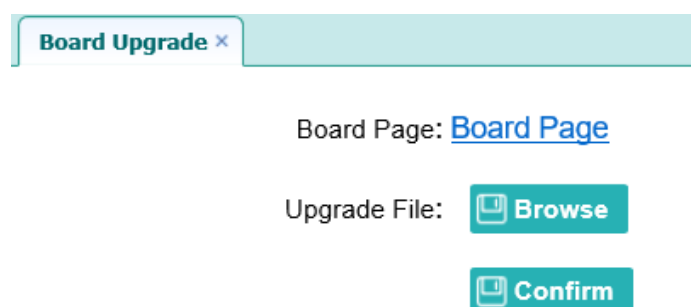

Board Upgrade x

Board Page: [Board Page](#)

Upgrade File:  **Browse**

 **Confirm**

### (8) Upgrade Online

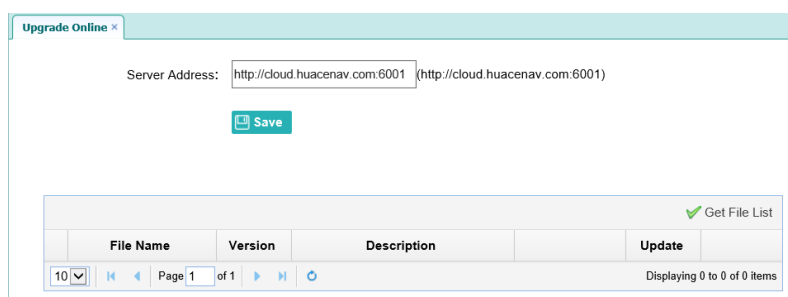

Upgrade Online x

Server Address:  (http://cloud.huacenav.com:6001)

 **Save**

 **Get File List**

File Name	Version	Description	Update
-----------	---------	-------------	--------

Page 1 of 1

Displaying 0 to 0 of 0 items

### (9) GNSS Registration

Use this submenu to register the receiver. Paste or enter the registration code to the **Registration Code** field → click **[Registration]** button to complete the registration.

GNSS Registration x

Serial Number: 1044385

Registration Limit: 2021-11-1

Registration Code: 44427-07761-06810

 Registration

## 7 Default Setting and Configuration Files

Most of the receiver settings are stored in application files. The default application file, Default.cfg, is stored permanently in the receiver and contains the factory default settings for the P5 GNSS reference receiver.

Whenever the receiver is reset to its factory defaults, the current settings (stored in the current configuration file, copy.cfg) are reset to the values in the default application file.

The P5 GNSS reference receiver extends the use of configuration files to allow simplified receiver is setting duplication in multiple receivers. This is sometimes referred to as **receiver cloning** and is very useful when preparing a large group of receivers for a field data collection campaign.

### 7.1.1 Default Receiver Settings

Function		Factory default values
SV Enable		All SVs enabled
General controls	Elevation mask PDOP mask	0° 6
LEMO port	Baud rate Format  Flow control	9600 9-None-1(10-pin)  None
DB9 port	Baud rate Format Flow control	9600 3-None-6 None
Log status		OFF
Differential data		OFF
Raw data		OFF
Ephemeris data		OFF
NMEA (GPGGA, GPGSV)		OFF
Reference position	Latitude Longitude Height	0°0'0.00000000'' 0°0'0.00000000'' 0.000
Antenna	Type Measure Method Height	None Antenna Phase Center 2.0000 (Meter)

## 7.1.2 Resetting the Receiver to Factory Defaults

Log in the web page of the receiver → tap and unfold the **Receiver Reset** menu → tap the **Receiver Reset** submenu → click the [**Confirm**] button to the right of **Reset to Defaults** field.

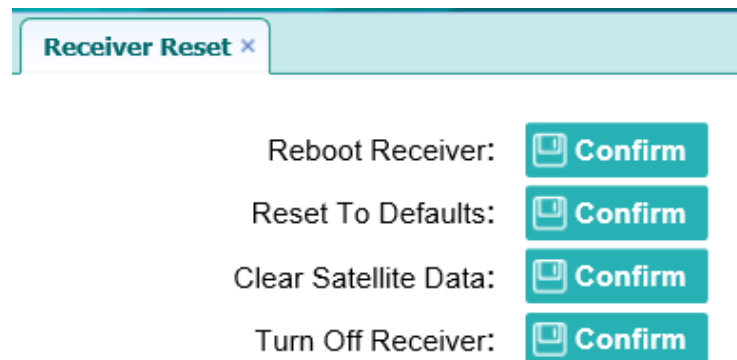

## 7.1.3 Using Configuration Files to Duplicate Receiver Settings

The P5 GNSS reference receiver allows the extensive use of application files to retain a unique receiver configuration. With this receiver, the user can create a configuration file that includes most of the receiver's unique configuration settings. The user can then update that configuration file onto one or more other P5 GNSS reference receivers to quickly configure them to match the receiver which creates that configuration file.

**Notes:** The configuration file includes most of the configuration settings except IP Address, IP Mask, Gateway and DNS Server.

This is called receiver configuration cloning or cloning. Receiver cloning greatly reduces the time required to prepare a large group of receivers for field operations.

Log in the web page of the receiver → tap and unfold the **Firmware** menu → tap the **Config File** submenu → click the [**Browse**] button to locate the existing configuration file → click [**Confirm**] button to confirm the selected file and start updating.

**Config File** ×

Download Configuration File : [Download](#)

Update Configuration File: [Browse](#)

[Confirm](#)

## 8 Specifications

This chapter describes the specifications for the P5 GNSS reference receiver.

Specifications are subject to change without notice.

### 8.1 GNSS Characteristics

Feature	Specification
Tracking	624 channels GPS: L1, L2C, L5 GLONASS: L1, L2 SBAS: L1 QZSS:L1, L5 Galileo: E1, E5A, E5B BDS: B1, B2, B3, B1c, B2a Pseudo-range measurement with high-precision multi-correlator Very low noise carrier phase measurements with < 1 mm precision in a 1 Hz bandwidth
Real Time Kinematic (RTK)	Horizontal: 8 mm + 1 ppm RMS Vertical: 15 mm + 1 ppm RMS
Post Processing Static	Horizontal: 2.5 mm + 0.5 ppm RMS Vertical: 5 mm + 0.5 ppm RMS
Post Processing Static (long observation)	Horizontal: 3 mm + 0.1 ppm RMS Vertical: 3.5 mm + 0.4 ppm RMS
Initialization time	Typically < 8 s
Initialization reliability	Typically > 99.9%

## 8.2 Communication

Feature	Specification
RJ45 Jack	Ethernet
DB9 male	3-wire RS232, see C.III. CHCNAV P5 receiver db9 male connector definition for details
COM2 (10-pin LEMO port)	9-wire RS232, see C.I. CHCNAV P5 receiver COM 2 (10-pin LEMO port) definition for details
LAN port	HTTP, TCP/IP, UDP, FTP, NTRIP Caster, NTRIP Server, NTRIP Client Simultaneously transmits multiple data stream Compatible with a proxy server and route table Compatible with Power over Ethernet (PoE)
USB port	Type-A USB receptacle operates in Host mode
GNSS port	GNSS ports provided by the receiver
Bluetooth	Fully integrated, fully sealed 2.4 GHz Bluetooth wireless technology Compatible with Android, Windows Mobile, and Windows desktop operating systems
Wi-Fi	802.11 b/g/n, access point mode
Protocols	Correction formats: CMR, RTCM 2.x, RTCM 3.x Observables: RINEX 2.x, RINEX 3.X, BINARY Position/Status I/O: NMEA-0183 output Met sensor
Internal data	Data logging and position output frequency up to 20 Hz Storage capacity 32 GB
External storage	Up to 1 TB
Network Modem (Internally integrated 4G modem)	LTE (FDD): B1, B3, B8, all bands with diversity LTE (TDD): B38, B39, B40, B41, all bands with diversity DC-HSPA+/HSPA+/HSPA/UMTS: B1, B5, B8, B9, all bands with diversity TD-SCDMA: B34, B39 EDGE/GPRS/GSM 900/1800 MHz

## 8.3 Physical

Feature	Specification
Size (L x W x H)	200 x 150 x 69 mm (7.9 x 5.9 x 2.7 in)
Weight	2.15 kg (75.8 oz)
Operating temperature	-40 °C to +65 °C (-40 °F to +149 °F)
Storage temperature	-45 °C to +80 °C (-49°F to 176°F)
Humidity	100% condensation
Water and Dustproof	Tested to IP67; waterproof for temporary immersion to a depth of 1 m (3.28 ft) for 30 minutes; dustproof
Shock and Vibration	Designed to survive a 1 m (3.28 ft) drop onto concrete

## 8.4 Electrical

Feature	Specification
Power consumption	5W nominal, dependent on user settings
Internal	<p>Integrated internal battery 7.4 V, 17000 mA-h, Lithium-ion</p> <p>Internal battery can operate as a UPS in the event of external power source outage</p> <p>The internal battery will charge from the external power source when the internal battery is not fully charged</p>
External power	<p>Power source supply (Internal / External) is hot swap capable in the event of power source removal or cut-off</p> <p>Power input on LEMO ports is 9 V DC to 36 V DC external power input</p> <p>The receiver auto powers on when connected to external power with a voltage above 11 V</p>
Operation time on internal battery	Up to 24 hours continuous operation, dependent on user setting

## 8.5 General

Feature	Specification
Front panel display	Power button and indicator LED Escape, OK and 4 arrow keys (up, down, left, right) USB port and 4G slot LCD
Receiver type	GNSS reference receiver
Antenna type	CHCNAV AT312 GNSS Geodetic antenna or CHCNAV C220GR2 GNSS Choke Ring antenna preferred. Other models supported.

## 8.6 Data storage

Feature	Specification
Internal storage	32 GB
External storage	Supporting USB drive or portable hard drive
Storage method	8-thread logging, circulating data logging
Data format	HCN, RINEX, original binary data
Data download	FTP push, online download, storage on an external USB device

## A. Upgrading the Receiver Firmware

The receiver is supplied with the latest version of the receiver firmware already installed. If a later version of the firmware becomes available, use the USB device to upgrade the firmware on the user's receiver. For the latest firmware resource, please consult the user's local CHCNAV dealer.

The user can also upgrade the receiver through the web interface. The firmware file required to upgrade the receiver through the Web interface in the folder where the user saves the file. The file type required is the format update\_P5\_e\_vXXXXX\_bYYYYMMDD.bin where XXXXX represents the version of firmware and YYYYMMDD represents the firmware encapsulation date.

### A.I. Upgrading the Receiver Firmware

#### A.I.i. Upgrading through the USB Port

- (1) Copy the firmware file to the root directory of external storage device such as USB drive, portable hard drive.
- (2) Connect the external storage device with the receiver through the USB port.
- (3) Restart the receiver, and then the screen will prompt the user whether to upgrade the firmware.
- (4) Press **OK** button to upgrade the firmware.
- (5) When the upgrading is completed, the receiver will be restarted, and the screen will prompt the user whether to upgrade the firmware again.
- (6) Press one of the arrow keys to quit the upgrading and then remove the external storage device.

#### A.I.ii. Upgrading through A Browser

Please connect to the receiver through a web browser according to **6.2. Configuring through a web browser**, and then refer to **6.2.1.9 Firmware menu** → **Firmware Update** for detail operation steps.

**Notes:** After the receiver firmware upgrading, the IP information may be changed. Please confirm the IP setting of the receiver before using it.

## B. Troubleshooting

Use this appendix to identify and solve common problems that may occur during the use of the receiver.

Please read this section before contact CHCNAV Technical Support.

### B.I. Receiver Issues

This section describes some possible receiver issues, possible causes, and how to solve them.

Issue	Possible cause	Solution
The receiver does not turn on.	External power is too low.	Check the charge on the external battery and, if applicable, check the fuse.
	Internal power is too low.	Check the charge on the internal battery.
	External power is not properly connected.	Check that the LEMO connector is seated correctly and that the cable is secured to the receiver. Check for broken or bent pins in the connector.
	Faulty power cable.	Check that the user is using the correct cable for the connection between LEMO port and external power supply. Check that the correct external power supply is connected to a particular LEMO port. Check pinouts with a multimeter to ensure the internal wiring is intact.
The receiver does not log data.	The receiver is tracking fewer than four	Wait until the receiver display shows that more

	<b>satellites.</b>	<b>than four satellites are tracked.</b>
<b>The receiver is not responding.</b>	<b>The receiver needs a soft reset.</b>	<b>Turn off the receiver and then turn it back on again.</b>
<b>The receiver is not receiving satellite signals</b>	<b>The GNSS antenna cable is loose.</b>	<b>Make sure that the GNSS antenna cable is tightly seated in the antenna connector on the GNSS antenna.</b>
	<b>The cable is damaged.</b>	<b>Check the cable for any signs of damage. A damaged cable can inhibit signal detection from the antenna at the receiver.</b>
	<b>The GNSS antenna is not in clear line of sight to the sky.</b>	<b>Make sure that the GNSS antenna is located with a clear view of the sky. Restart the receiver as a last resort (turn off and then turn it on again).</b>

## C. Communication Ports Definition

### C.I. CHCNAV P5 Receiver COM (10-PIN LEMO Port) Definition

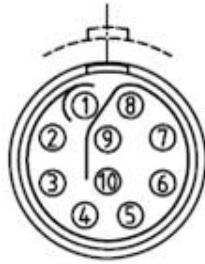

PIN	Signal Name	Description
1	RXD	RS232-TX (receive data through this pin)
2	TXD	RS232-TX (transmit data through this pin)
3	PWR	Eternal Power Input (Positive Pole)
4	PWR	Eternal Power Input (Positive Pole)
5	PWR, GND	Eternal Power Input (Negative Pole), External Power Ground
6	PWR, GND	Eternal Power Input (Negative Pole), External Power Ground
7	VBUS	USB Device
8	DM	USB Device
9	DP	USB Device
10	Not Used	

## C.II. CHCNAV P5 Receiver DB9 Male Connector Definition

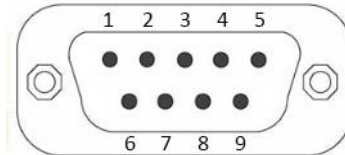

PIN	Signal Name	Description
1	Not Used	
2	TXD	RS232-TX (transmit data through this pin)
3	RXD	RS232-RX (receive data through this pin)
4	Not Used	
5	GND	External Power Ground
6	Not Used	
7	Not Used	
8	Not Used	
9	Not Used	

## D. Glossary

Terms	Description
Base Station	Also called reference station. A base station in construction is a receiver placed at a known point on a job site that tracks the same satellites as an RTK rover and provides a real-time differential correction message stream through the radio to the rover, to obtain centimeter level positions on a continuous real-time basis. A base station can also be a part of a virtual reference station network or a location at which GPS observations are collected over a period, for subsequent postprocessing to obtain the most accurate position for the location.
Carrier	A radio wave is having at least one characteristic (such as frequency, amplitude, or phase) that can be varied from a known reference value by modulation.
Carrier Frequency	It means the frequency of the unmodulated fundamental output of a radio transmitter. The GPS L1 carrier frequency is 1575.42 MHz.
Carrier Phase	The time is taken for the L1 or L2 carrier signal generated by the satellite to reach the GPS receiver. Measuring the number of carrier waves between the satellite and receiver is a very accurate method of calculating the distance between them.
CMR CMR+	Compact Measurement Record. A real-time message format developed by Trimble for broadcasting corrections to other Trimble mainboard receivers. CMR is a more efficient alternative to RTCM.
DGPS	See real-time differential GPS.
Differential Correction	Differential correction is the process of correcting GPS data collected on a rover with data collected

	<p>simultaneously at a base station. Because the base station is in a known location, any errors in data collected at the base station can be measured, and the necessary corrections applied to the rover data.</p> <p>Differential correction can be done in real-time, or after the data has been collected by postprocessing.</p>
Differential GPS	See real-time differential GPS.
DOP	<p>Dilution of Precision. A measure of the quality of GPS positions, based on the geometry of the satellites used to compute the positions. When satellites are widely spaced relative to each other, the DOP value is lower, and position accuracy is greater. When satellites are close together in the sky, the DOP is higher, and GPS positions may contain a greater level of error.</p> <p>PDOP (Position DOP) indicates the three-dimensional geometry of the satellites. Other DOP values include HDOP (Horizontal DOP) and VDOP (Vertical DOP), which indicate the accuracy of horizontal measurements (latitude and longitude) and vertical measurements respectively. PDOP is related to HDOP and VDOP as follows:</p> $PDOP^2 = HDOP^2 + VDOP^2$
Dual-Frequency GPS	A type of receiver that uses both L1 and L2 signals from GPS satellites. A dual-frequency receiver can compute more precise position fixes over longer distances and under more adverse conditions because it compensates for ionospheric delays.
EGNOS	<p>European Geostationary Navigation Overlay Service. A satellite-based augmentation system (SBAS) that provides a free-to-air differential correction service for GPS.</p> <p>EGNOS is the European equivalent of WAAS, which is available in the United States.</p>
Elevation Mask	The angle below which the receiver will not track

	satellites. Normally set to 10 degrees to avoid interference problems caused by buildings and trees, and multipath errors.
Ephemeris/Ephemerides	<p>A list of predicted (accurate) positions or locations of satellites as a function of time. It contains a set of numerical parameters that can be used to determine a satellite's position.</p> <p>Available as broadcast ephemeris or as postprocessed precise ephemeris.</p>
Epoch	The measurement interval of a GPS receiver. The epoch varies according to the measurement type: for real-time measurement, it is set at one second; for post-processed measurement, it can be set to a rate of between one second and one minute. For example, if data is measured every 15 seconds, loading data using 30-second epochs means loading every alternate measurement.
Firmware	The program inside the receiver that controls receiver operations and hardware.
GLONASS	Global Orbiting Navigation Satellite System. GLONASS is a Soviet space-based navigation system comparable to the American GPS system. The operational system consists of 21 operational and 3 non-operational satellites in 3 orbit planes.
GNSS	Global Navigation Satellite System.
GSOFF	General Serial Output Format. A Trimble proprietary message format.
HDOP	<p>Horizontal Dilution of Precision. HDOP is a DOP value that indicates the accuracy of horizontal measurements. Other DOP values include VDOP (vertical DOP) and PDOP (Position DOP).</p> <p>Using a maximum HDOP is ideal for situations where vertical precision is not particularly important, and the</p>

	user's position yield would be decreased by the vertical component of the PDOP ( for example, if the user is collecting data under canopy).
L1	The primary L-band carrier used by GPS satellites to transmit satellite data.
L2	The secondary L-band carrier used by GPS satellites to transmit satellite data.
L5	The third L-band carrier used by GPS satellites to transmit satellite data. L5 will provide a higher power level than the other carriers. As a result, acquiring and tracking weak signals will be easier.
MSAS	MTSAT Satellite-Based Augmentation System. A satellite-based augmentation system (SBAS) that provides a free-to-air differential correction service for GPS. MSAS is the Japanese equivalent of WAAS, which is available in the United States.
Multi-Frequency GPS	A type of receiver that uses multiple carrier phase measurements (L1, L2, and L5) from different satellite frequencies.
Multipath	Interference, similar to ghosts on a television screen that occurs when GPS signals arrive at an antenna having traversed different paths. The signal traversing the longer path yields a larger pseudorange estimate and increases the error. Multiple paths can arise from reflections off the ground or off structures near the antenna.
MEA	National Marine Electronics Association. NMEA 0183 defines the standard for interfacing marine electronic navigational devices. This standard defines several 'strings' referred to as NMEA strings that contain navigational details such as positions. Most CHCNAV GPS receivers can output positions as NMEA strings.

PDOP	<p>Position Dilution of Precision. PDOP is a DOP value that indicates the accuracy of three-dimensional measurements. Other DOP values include VDOP (vertical DOP) and HDOP (Horizontal Dilution of Precision).</p> <p>Using a maximum PDOP value is ideal for situations where both vertical and horizontal precision is important.</p>
Postprocessing	<p>Postprocessing is the processing of satellite data after it has been collected, in order to eliminate the error. This involves using computer software to compare data from the rover with data collected at the base station.</p>
Real-Time Differential GPS	<p>Also known as a real-time differential correction or DGPS. Real-time differential GPS is the process of correcting GPS data as the user collect it. Corrections are calculated at a base station and then sent to the receiver through a radio link. As the rover receives the position, it applies the corrections to give the user a very accurate position in the field.</p> <p>Most real-time differential correction methods apply corrections to code phase positions. RTK uses carrier phase measurements.</p> <p>While DGPS is a generic term, its common interpretation is that it entails the use of single-frequency code phase data sent from a GPS base station to a rover GPS receiver to provide sub-meter position accuracy. The rover receiver can be at a long range (greater than 100 km (62 miles)) from the base station.</p>
Reference Station	See base station
Rover	<p>A rover is any mobile GPS receiver that is used to collect or update data in the field, typically at an unknown location.</p>
RTCM	Radio Technical Commission for Maritime Services. A

	<p>commission established to define a differential data link for the real-time differential correction of roving GPS receivers. There are three versions of RTCM correction messages. All CHCNAV GPS receivers use Version 2 protocol for single-frequency DGPS type corrections. Carrier phase corrections are available on Version 2, or on the newer Version 3 RTCM protocol, which is available on certain CHCNAV dual-frequency receivers. The Version 3 RTCM protocol is more compact but is not as widely supported as Version 2.</p>
RTK	<p>Real-time kinematic. It is a real-time differential GPS method that uses carrier phase measurements for greater accuracy.</p>
SBAS	<p>Satellite-Based Augmentation System. SBAS is based on differential GPS but applies to wide area (WAAS/EGNOS and MSAS) networks of reference stations. Corrections and additional information are broadcast via geostationary satellites.</p>
Signal-To-Noise Ratio	<p>SNR. The signal strength of a satellite is a measure of the information content of the signal, relative to the signal's noise. The typical SNR of a satellite at 30° elevation is between 47 and 50 dBHz. The quality of a GPS position is degraded if the SNR of one or more satellites in the constellation falls below 39.</p>
Skyplot	<p>The satellite skyplot confirms reception of a differentially corrected GPS signal and displays the number of satellites tracked by the GPS receiver, as well as their relative positions.</p>
SNR	<p>See signal-to-noise ratio</p>
UTC	<p>Universal Time Coordinated. A time standard based on the local solar mean time at the Greenwich meridian.</p>
VRS	<p>Virtual Reference Station. A VRS system consists of GNSS hardware, software, and communication links. It uses data from a network of reference stations to</p>

	<p>provide corrections to each rover that are more accurate than corrections from a single base station.</p> <p>To use the VRS corrections, the rover sends its position to the VRS server. The VRS server uses the reference station data to model systematic errors (such as ionospheric delay) at the rover position. It then sends RTCM or CMR correction messages back to the rover.</p>
<p>WAAS</p>	<p>Wide Area Augmentation System. WAAS was established by the Federal Aviation Administration (FAA) for flight and approach navigation for civil aviation. WAAS improves the accuracy and availability of the basic GPS signals over its coverage area, which includes the continental United States and outlying parts of Canada and Mexico.</p> <p>The WAAS system provides correction data for visible satellites. Corrections are computed from ground station observations and then uploaded to two geostationary satellites. This data is then broadcast on the L1 frequency and is tracked using a channel on the GPS receiver, exactly like a GPS satellite.</p> <p>Use WAAS when other correction sources are unavailable, to obtain greater accuracy than autonomous positions. For more information on WAAS, refer to the FAA website at <a href="http://gps.faa.gov">http://gps.faa.gov</a>.</p> <p>The EGNOS service is the European equivalent, and MSAS is the Japanese equivalent of WAAS.</p>



CHCNAV - Shanghai Huace Navigation Technology Ltd.

577 Songying Road, Building C

Shanghai, 201703, China

Tel: +86 21 542 60 273

Fax: +86 21 649 50 963

**Email:** | [support@chcnav.com](mailto:support@chcnav.com)

**Website:** [www.chcnav.com](http://www.chcnav.com)

**Make** your work more efficient